

<b>Section 0.0</b>	■ <b>Warnings</b> .....	2
<b>Section 1.0</b>	■ <b>Quick Set-up</b> .....	3
<b>Section 2.0</b>	■ <b>Description</b> .....	4
<b>Section 3.0</b>	■ <b>Installation</b>	
	3.1 Mechanical Installation .....	6
	3.2 Ventilation .....	6
	3.3 General Layout .....	6
	3.4 Power Wiring - Standard Connection .....	7
	3.5 Power Wiring - Bypass Connection .....	7
	3.6 Power Wiring - D.C.Brake Connection .....	8
	3.7 Power Wiring – Inside Delta Connection .....	8
	3.8 Control Supply Voltage .....	8
	3.9 Control Wiring .....	9
	3.10 Motor Thermistors .....	10
	3.11 Control Circuit Examples .....	10
	3.12 Serial Communications .....	11
<b>Section 4.0</b>	■ <b>Programming</b>	
	4.1 Programming Procedure .....	16
	4.2 Programmable Functions .....	16
<b>Section 5.0</b>	■ <b>Operation</b>	
	5.1 Local Control Panel .....	27
	5.2 Remote Control .....	27
	5.3 Serial Communications .....	28
	5.4 Restart Delay .....	28
	5.5 Secondary Parameter Set .....	28
	5.6 Motor Thermal Model .....	28
	5.7 Pre-start Tests .....	28
	5.8 Operation After Power Loss .....	28
<b>Section 6.0</b>	■ <b>Specifications</b>	
	6.1 General Technical Data .....	29
	6.2 Current Ratings .....	30
	6.3 Power Termination Details .....	31
	6.4 Semi-conductor Fuses .....	31
	6.5 Dimensions/Weights .....	32
<b>Section 7.0</b>	■ <b>Design Guide</b>	
	7.1 Reduced Voltage Starting .....	33
	7.2 Types Of Soft Start Control .....	34
	7.3 MCD3000 Control Principles .....	34
	7.4 Understanding Soft Starter Ratings .....	34
	7.5 Model Selection .....	35
	7.6 Typical Applications .....	36
	7.7 Power Factor Correction .....	38
	7.8 Line Contactors .....	38
	7.9 Soft Braking .....	38
<b>Section 8.0</b>	■ <b>Fault Procedure</b>	
	8.1 Trip Codes .....	39
	8.2 Trip Log .....	40
	8.3 General Faults .....	41
	8.4 Tests and Measurement Procedures .....	42



The MCD3000 contains dangerous voltages when connected to line voltage. Only a competent electrician should carry out the electrical installation. Improper installation of the motor or the MCD3000 may cause equipment failure, serious injury or death. Follow this manual and National Electrical Codes (NEC®) and local safety codes.

---

**■ Safety regulations**

1. The soft starter must be disconnected from the mains if repair work is to be carried out.
2. The [STOP] on the control panel of the soft starter does not disconnect the equipment from the mains and thus is not to be used as a safety switch.



It is the responsibility of the user or the person installing the MCD3000 to provide proper grounding and branch circuit protection according to the National Electric Code (NEC®) and local codes.

**■ Warning against unintended start**

1. The motor can be brought to a stop by means of digital commands, bus commands or a local stop, while the soft starter is connected to the mains. If personal safety considerations make it necessary to ensure that no unintended start occurs, these stop functions are not sufficient.
2. A motor that has been stopped may start if faults occur in the electronics of the soft starter, or if the soft starter's Auto Reset function has been activated and a temporary fault in the supply mains or the motor connection ceases.

**■ Symbols used in this manual**

When reading this manual you will come across different symbols that require special attention. The symbols used are the following:



Indicates something to be noted by the reader



Indicates a general warning



Indicates a high voltage warning

**■ Avoiding soft starter damage**

Please read and follow all instructions in this manual. Additionally, take special note of the following:

1. Do not connect power factor correction capacitors to the soft starter output. Static power factor correction, if used, must be connected on the mains side of the soft starter.
2. Do not apply voltage to the MCD3000 control inputs. The inputs are active 24 VDC and must be controlled with potential free circuits.
3. When installed in non-ventilated enclosures, soft starters should be used with a bypass contactor to prevent excessive enclosure temperatures.
4. When bypassing a soft starter take care to ensure phase connections are correct. i.e. B1-T1, L2-T2, B3-T3.
5. When using the D.C.Brake function ensure the D.C.Braking contactor is connected across output terminals T2-T3 only and that it operates only when the braking function is operating. Incorrect connection or operation will cause soft starter damage.



Electrostatic Precaution: Electrostatic discharge (ESD). Many electronic components are sensitive to static electricity. Voltages so low that they cannot be felt, seen or heard, can reduce the life, affect performance, or completely destroy sensitive electronic components. When performing service, proper ESD equipment should be used to prevent possible damage from occurring.

## ■ Quick Set-up

For basic start/stop control only three steps are required to commission the MCD3000.

- Install the MCD3000
- Program the MCD3000
- Start the motor.

The MCD3000 provides many other features that enable users to customise operation for their particular requirements. To learn more about these features please study this manual.

## ■ Install the MCD3000



Mounting, wiring and setting the soft starter into operation must be carried out properly by trained personnel.

1. Verify that the ratings of the MCD3000 are correct for the application.
2. Physically install the MCD3000. (Refer to the Installation section of this manual)
3. Connect mains, motor, motor thermistor (if any) and control voltage circuits as shown below.

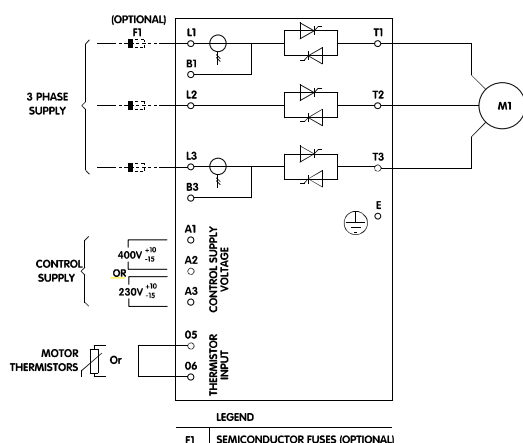

The voltage of the soft starter is dangerous whenever the equipment is connected to the mains. Ensure the soft starter is correctly connected and that all safety measures have been taken before switching on the supply.

4. Turn on the supply.

## ■ Program the MCD3000

For simple applications the MCD3000 needs only to be programmed with the FLC (Full Load Current) of the connected motor.

To program the MCD3000 with the motor FLC do the following:

1. Enter the programming mode by pressing the [MENU/CANCEL] button on the Local Control Panel. The display will show the number of the first programming parameter, Par.1 *Motor FLC*
2. Press the [CHANGE DATA/OK] button to display the programmed value. The setting may now be adjusted.
3. Using the [+/-] buttons adjust the setting to match the motor FLC.
4. When correct, store the Motor FLC setting by pressing the [CHANGE DATA/OK] button (Pressing the [MENU/CANCEL] button returns you to the parameter number without saving the new value).
5. Return the MCD3000 to run mode by pressing the [MENU/CANCEL] button.

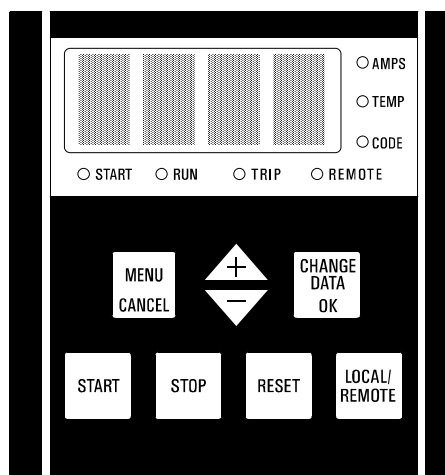

## ■ Start the motor

With the motor FLC programmed, the motor can now be started using the MCD3000 [START] button.

Other commonly used functions that may be useful in a Quick Set-up situation include:

- Par. 5 *Soft Stop* (Refer to the Programming section of this manual for a description)
- Par. 2 *Current Limit* (Refer to the Programming section of this manual for a description)

If required, set these parameters in the same manner as described for Par 1. *Motor FLC*

### ■ Description

The Danfoss MCD3000 Soft Starter is an advanced electronic motor starting system. It performs four main functions;

1. Start control.
2. Stop control, including both soft stop (extended stop time) and braking (reduced stop time).
3. Electronic motor protection.
4. Monitoring & system interface.

Models MCD3007 - 3132 are IP21 (NEMA 1) rated and have a local control panel that includes start, stop & reset push buttons. They are suitable for wall mounting, or installation in a switchboard.

Models MCD3185 - 3800 have an IP20 rating and must be installed in a switchboard or other enclosure. The MCD3000 Soft Starters are complete and require no optional modules to add functionality.

Automatic detection and calibration for supply voltage and frequency eliminates the need for special models.

MCD3000 Soft starters are available with two maximum voltage ratings.

- 200 VAC ~ 525 VAC
- 200 VAC ~ 690 VAC

The power circuit uses reverse parallel connected thyristors to provide full wave control on all three phases. The MCD3000 can be used with or, if local regulations permit, without a line contactor.

### ■ Ordering type code

**MCD 3**       -       -       -      

Nominal Motor kW @ 400V  
e.g. 55kW = 3055  
185kW = 3185

Maximum Voltage Rating  
e.g. T5 = 525 VAC  
T7 = 690 VAC\*

Enclosure  
B21 = Bookstyle IP21  
C20 = Compact IP20  
C21 = Compact IP21

Control Supply Voltage  
CV4 = 230 VAC & 400 VAC

\* UL & C-UL approval for T7 models is applicable where the supply voltage is 600V or less

MCD3000 Model	Rated Current (Amps) AC53a 3-30:50-10	Dimensions mm (inches)			Protection Format
		Height	Width	Depth	
MCD3007	20	530 (20.87)	132 (5.20)	270 (10.63)	IP21 Book style (B21)
MCD3015	34	530 (20.87)	132 (5.20)	270 (10.63)	IP21 Book style (B21)
MCD3018	39	530 (20.87)	132 (5.20)	270 (10.63)	IP21 Book style (B21)
MCD3022	47	530 (20.87)	132 (5.20)	270 (10.63)	IP21 Book style (B21)
MCD3030	68	530 (20.87)	132 (5.20)	270 (10.63)	IP21 Book style (B21)
MCD3037	86	530 (20.87)	132 (5.20)	270 (10.63)	IP21 Book style (B21)
MCD3045	93	530 (20.87)	132 (5.20)	270 (10.63)	IP21 Book style (B21)
MCD3055	121	530 (20.87)	132 (5.20)	270 (10.63)	IP21 Book style (B21)
MCD3075	138	530 (20.87)	264 (10.40)	270 (10.63)	IP21 Compact (C21)
MCD3090	196	530 (20.87)	264 (10.40)	270 (10.63)	IP21 Compact (C21)
MCD3110	231	530 (20.87)	264 (10.40)	270 (10.63)	IP21 Compact (C21)
MCD3132	247	530 (20.87)	396 (15.60)	270 (10.63)	IP21 Compact (C21)
MCD3185	364	850 (33.46)	430 (16.93)	280 (11.02)	IP20 Compact (C20)
MCD3220	430	850 (33.46)	430 (16.93)	280 (11.02)	IP20 Compact (C20)
MCD3300	546	850 (33.46)	430 (16.93)	280 (11.02)	IP20 Compact (C20)
MCD3315	630	850 (33.46)	430 (16.93)	280 (11.02)	IP20 Compact (C20)
MCD3400	775	850 (33.46)	430 (16.93)	280 (11.02)	IP20 Compact (C20)
MCD3500	897	850 (33.46)	430 (16.93)	280 (11.02)	IP20 Compact (C20)
MCD3600	1153	1000 (39.37)	560 (22.05)	315 (12.40)	IP20 Compact (C20)
MCD3700	1403	1000 (39.37)	560 (22.05)	315 (12.40)	IP20 Compact (C20)
MCD3800	1564	1000 (39.37)	560 (22.05)	315 (12.40)	IP20 Compact (C20)

■ Functions

Function	Related Parameters
Starting	
• Current Limit	2
• Current Ramp	3 & 4
• Torque Boost	16
• Torque Control	16
Stopping	
• Soft Stop	5
• Pump Control	17
• D.C. Brake	18 & 19
Protection	
• Motor Overload	6
• Phase Imbalance	7, 12 & 31
• Undercurrent	8, 13 & 32
• Instantaneous Overload	9, 14 & 33
• Phase Rotation	11
• Restart Delay	15
• Motor Thermistor	-
• Power Circuit Tests	-
• Shorted SCR	-
• Starter Heatsink Overtemperature	-
• Supply Frequency	-
• RS485 Comms Error	24
Interface	
• Local Control Panel	20
• Remote Inputs	20
• Serial Communications (RS485)	22, 23 & 24
• Programmable Relay Outputs	36, 37 & 38
Sundry	
• Password Protection	46, 47 & 48
• Dual Parameter Set	25 - 33
• Trip Log	45
• High & Low Current Flags	34 & 35
• Automatic Reset	39, 40, 41 & 42
• Current Display	-
• Motor Temperature Display	-
• Reset parameters to default settings	49
• Program starter via serial link	-

■ Electrical Schematic

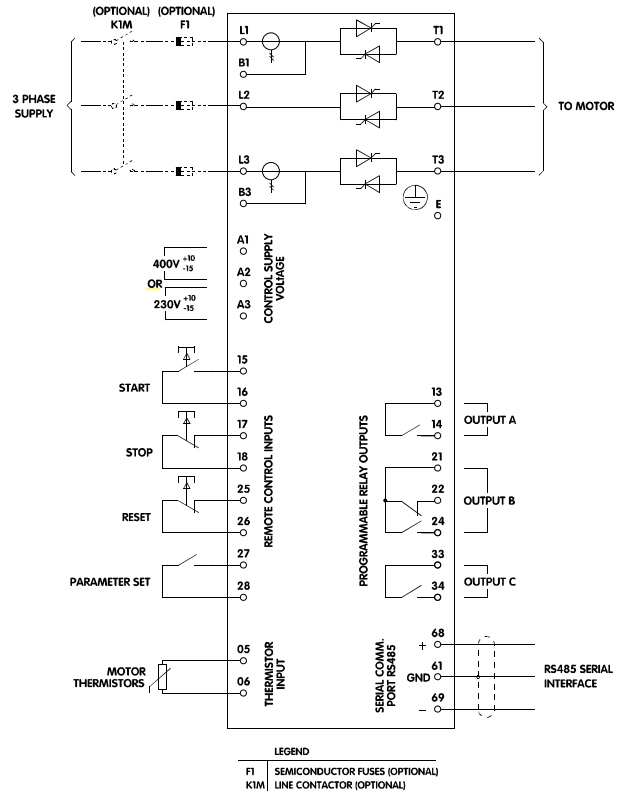

■ **Mechanical installation**

Models MCD3007~3132 have an IP21 rating and can be wall mounted or installed inside another enclosure. These models can be mounted side by side with no clearance.

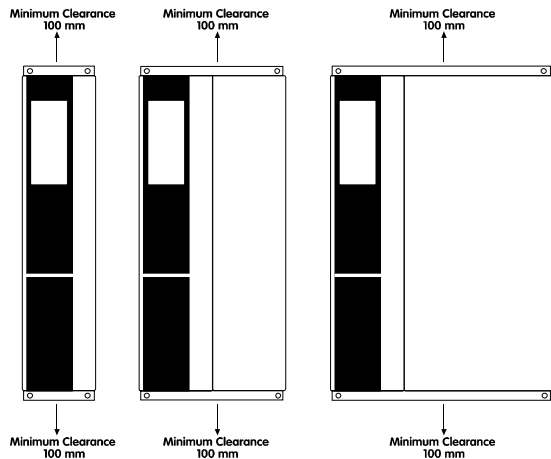

Models MCD3185~3800 have an IP20 rating and must be mounted in another enclosure. These models must have a clearance of 100mm on either side.

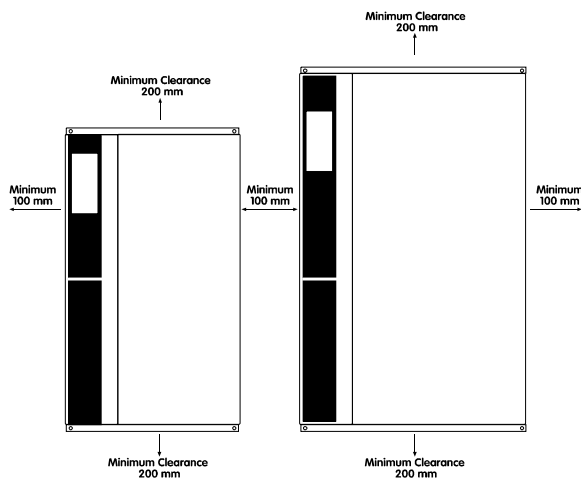

**ATTENTION**

Do not mount in direct sunlight or near heat radiating elements.

■ **Ventilation**

MCD3000 cooling is by means of air circulation. Consequently, the air needs to be able to move freely above and below the soft starter. Soft starters dissipate approximately 4.5 watts per amp. When installing a soft starter in a switchboard or other enclosure, ensure there is sufficient airflow through the enclosure to limit heat rise in the enclosure.

The table below shows airflow requirements for selected motor currents.

Motor Amps	Heat (watts)	Required Airflow m <sup>3</sup> /min	
		5°C Rise	10°C Rise
10	45	0.5	0.2
20	90	0.9	0.5
30	135	1.4	0.7
40	180	1.8	0.9
50	225	2.3	1.1
75	338	3.4	1.7
100	450	4.5	2.3
125	563	5.6	2.8
150	675	6.8	3.4
175	788	7.9	3.9
200	900	9.0	4.5
250	1125	11.3	5.6
300	1350	13.5	6.8
350	1575	15.8	7.9
400	1800	18.0	9.0
450	2025	20.3	10.1
500	2250	22.5	11.3
550	2475	24.8	12.4
600	2700	27.0	13.5



**ATTENTION**

If other heat sources are installed in an enclosure with the MCD3000, this heat must also be considered when calculating required airflow.



**ATTENTION**

If the MCD3000 is installed in an enclosure without ventilation a bypass contactor should be employed to prevent heat dissipation during run.

■ **General layout**

MCD3007 ~ MCD3055

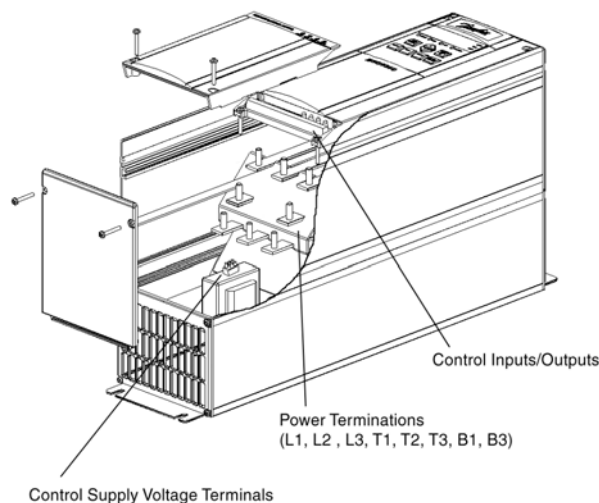

MCD3075 ~ MCD3110

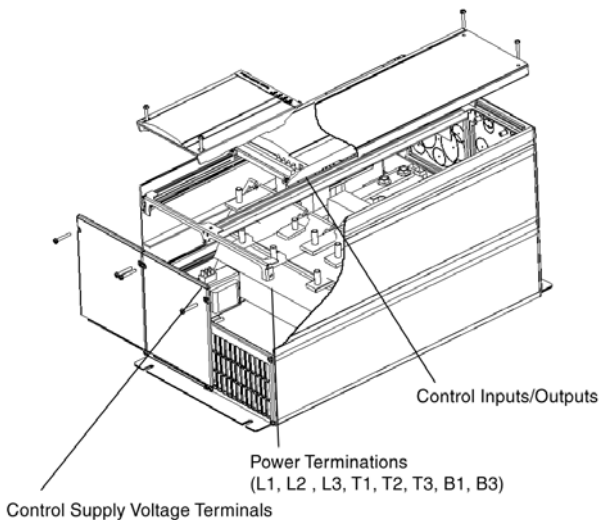

Use cables complying with local regulations.

### ■ Power wiring - Standard connection

Supply voltage must be connected to the starter input terminals L1, L2 & L3. The motor terminals must be connected to the soft starter output terminals T1, T2 & T3.

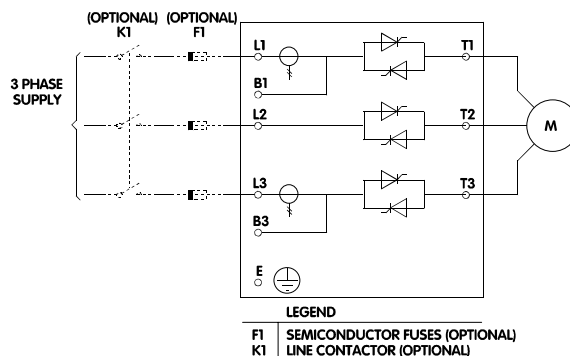

MCD3132

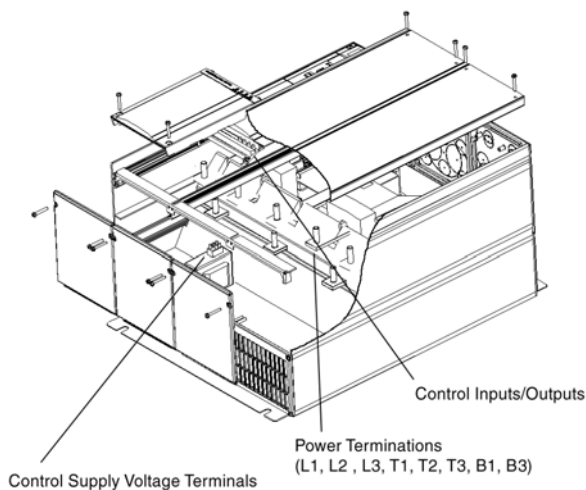

### ■ Power wiring - Bypass connection

A bypass contactor may be used to bypass the starter during run. A separate set of power terminals is provided within the MCD3000 for connection of the bypass contactor. These bypass terminals enable the MCD3000 to continue to provide all motor protection and current monitoring functions when the bypass contactor is closed.

Either Relay Output C or Relay Output A can be programmed to control operation of the bypass contactor.

Par. 36 Relay A - Function Assignment = 1 (Run)

Par. 38 Relay C - Function Assignment = 0 (Run)

MCD3185 ~ MCD3800

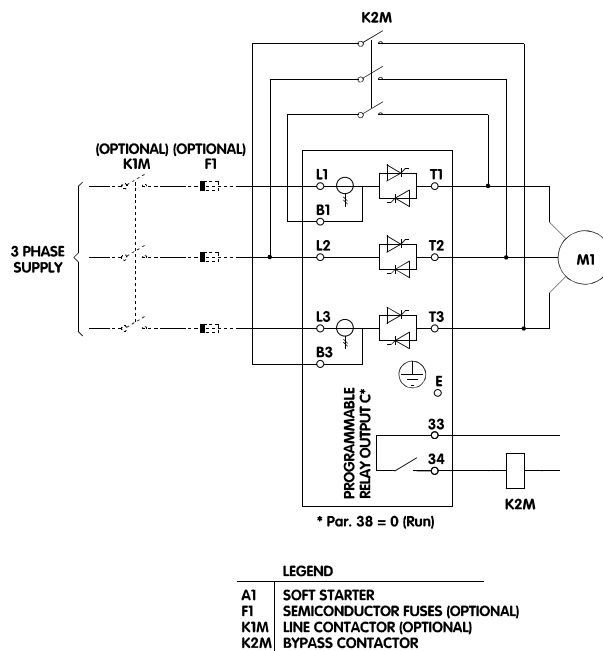
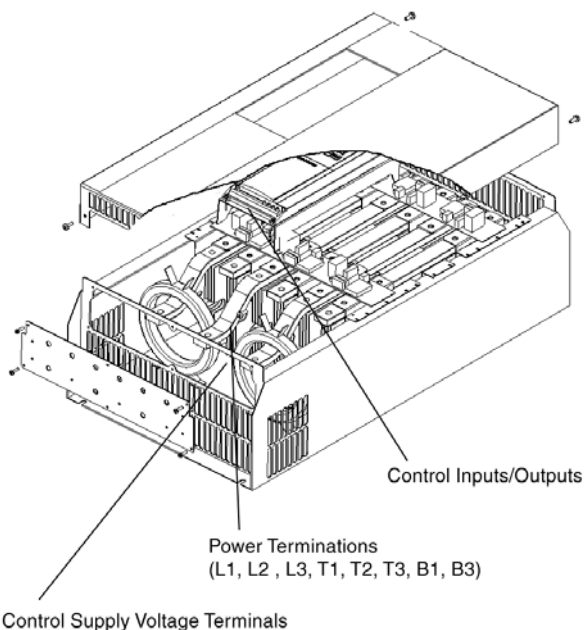



Failure to correctly connect the bypass contactor (B1-T1, L2,-T2, & B3-T3) will result in a loss of current based protection systems possibly leading to a motor failure.



Failure to correctly connect the bypass contactor (B1-T1, L2,-T2, & B3-T3) may result in a phase to phase short circuit causing severe equipment failure.

### ■ Power wiring - D.C.Brake connection

If the D.C.Braking function is to be used, a contactor must be wired to short output terminals T2 & T3 during the braking operation. This contactor must be controlled by the MCD3000 Relay Output C and Relay Output C must be programmed for D.C.Brake operation.

- Refer to Par. 18 and 19 for D.C.Brake parameter adjustments.
- Refer Par. 38 *Relay C - Function Assignment*.



The MCD3000 power modules will be damaged if the D.C.Brake contactor is closed when the D.C.Brake function is not operating, or if the .D.C.Brake contactor is incorrectly connected between T1-T2 or T1-T3.

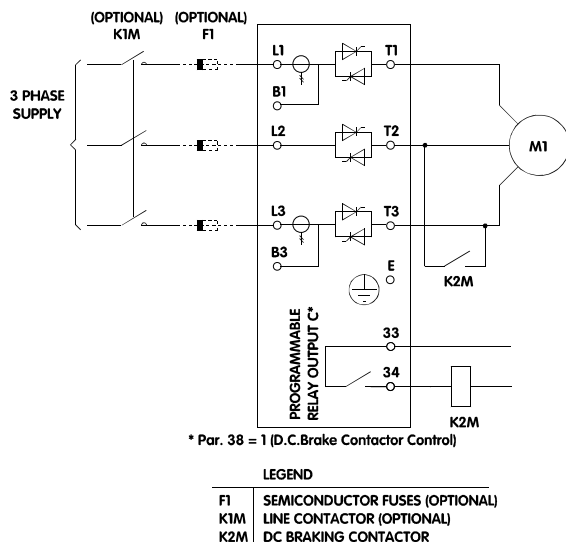

### ■ Power wiring – Inside delta connection

Models MCD3185 ~ MCD3800 can be connected inside the delta circuit of the motor when fitted with an optional Inside Delta Kit.

Soft starters connected within the delta circuit of a motor control only phase current thereby enabling them to be used with larger motors than would be possible with normal line connection. See the Specifications section of this manual for inside delta ratings.

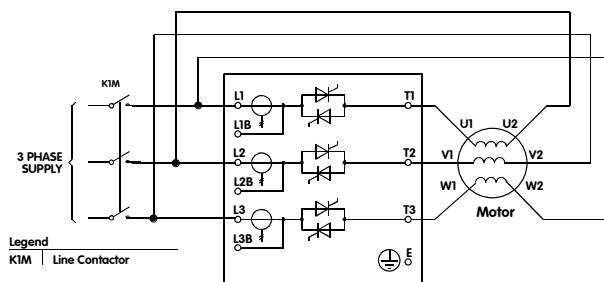

### ATTENTION

For inside delta connection to be possible both ends of all three motor windings must be accessible.



When utilizing the inside delta connection method voltage remains connected to one end of the motor windings even when the soft starter is in the off or tripped state. A line contactor or shunt trip activated circuit breaker must be used to totally isolate the motor in the event of a fault condition.

When fitted with one of the kits from the following table, MCD3000 units are inside delta capable. The inside delta capability is additional to all normal functionality and is totally automatic. No user adjustment or settings are required.

MCD3000 Model	Inside Delta Kit
MCD3185	175G3043
MCD3220	175G3044
MCD3300	175G3045
MCD3315	175G3046
MCD3400	175G3047
MCD3500	175G3048
MCD3600	175G3049
MCD3700	175G3050
MCD3800	175G3051

### ■ Control Supply Voltage

Voltage must be connected to the starter control voltage terminals. Control voltage can be either 230 VAC or 400 VAC (CV4)

400 VAC (+10% / -15%) { A1  
 or 230 VAC (+10% / -15%) { A2  
 { A3 } Electronics Supply



MCD3000 Model	Maximum VA
MCD3007~MCD3022	10VA
MCD3030~MCD3055	17VA
MCD3075~MCD3110	23VA
MCD3132~MCD3500	40VA
MCD3600~MCD3800	55VA

The following range of auto-transformers are available as optional accessories and can be fitted within the MCD3000 where other control voltages must be used.

Input Voltage	Part Number	
	MCD3007 ~ MCD3055	MCD3075 ~ MCD3800
110 VAC / 460 VAC	175G5084	175G5144
110 VAC / 575 VAC	175G5085	175G5145
24 VAC / 110 VAC	175G5087	175G5146



Removing control voltage from the MCD3000 resets the motor overload protection.

Two wire control example:

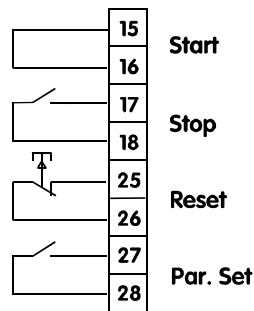

### ATTENTION

Simultaneously pressing the [STOP] and [RESET] buttons causes the MCD3000 to immediately remove voltage from the motor resulting in a coast to stop. Any soft stop or D.C.Brake settings are ignored.



Do not apply voltage to the control inputs. The inputs are active 24 VDC and must be controlled with potential free circuits.

### Control wiring

The MCD3000 can be controlled using the local push buttons, or via remote control inputs. Switch between the local and remote modes using the [LOCAL/REMOTE] push button.

The MCD3000 has four remote control inputs. Contacts used for controlling these inputs should be low voltage, low current rated (Gold flash or similar).

**The Stop and Reset circuits must be closed for the MCD3000 to run in remote control mode.**

Push button control example:

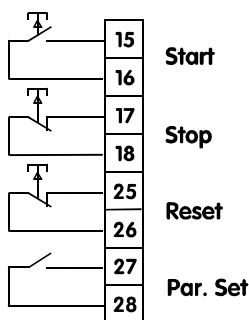

The Par. Set input determines which of the two MCD3000 motor parameter sets is operative. When a start is initiated the MCD3000 checks the state of the Par. Set input. If there is an open circuit the primary parameters (Par. 1 - 9) are operative. If there is a closed circuit the secondary parameters (Par. 25 - 33) are operative.

The MCD3000 provides three relay outputs.

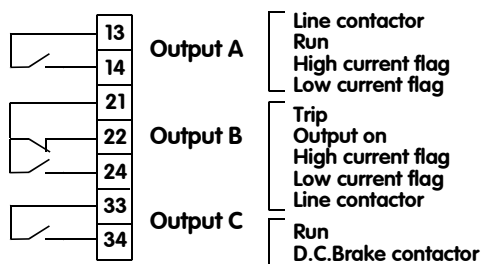

All outputs are programmable. Refer Par. 36, 37 & 38 *Relay Function Assignment*.

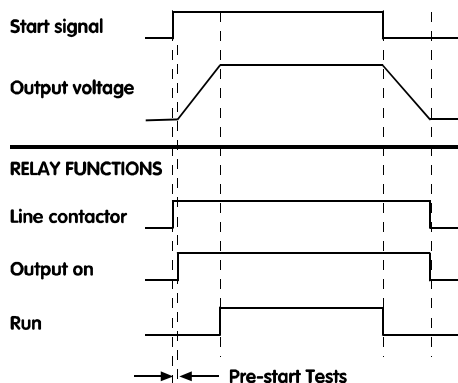

### Motor thermistors

If the motor is fitted with thermistors these may be connected directly to the MCD3000. A trip will occur if the thermistor circuit resistance is above approximately 2.8kΩ.

**If thermistors are not connected to the MCD3000 there must be a link across the thermistor input terminals.**

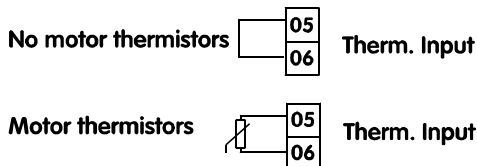

### Control circuit examples

Example 1. A basic installation where motor operation is controlled using the MCD3000 Local Control Panel.

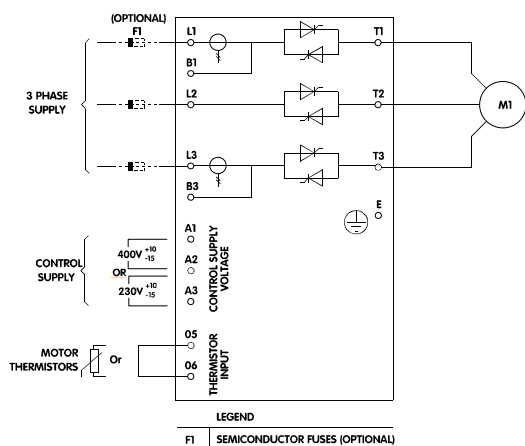

Notes:

1. The MCD3000 must be in local mode to function with this circuit. Use the [LOCAL/REMOTE] push button to switch between local and remote modes.

Example 2. MCD3000 installed with a line contactor and operated via a remote two wire start circuit with reset push button.

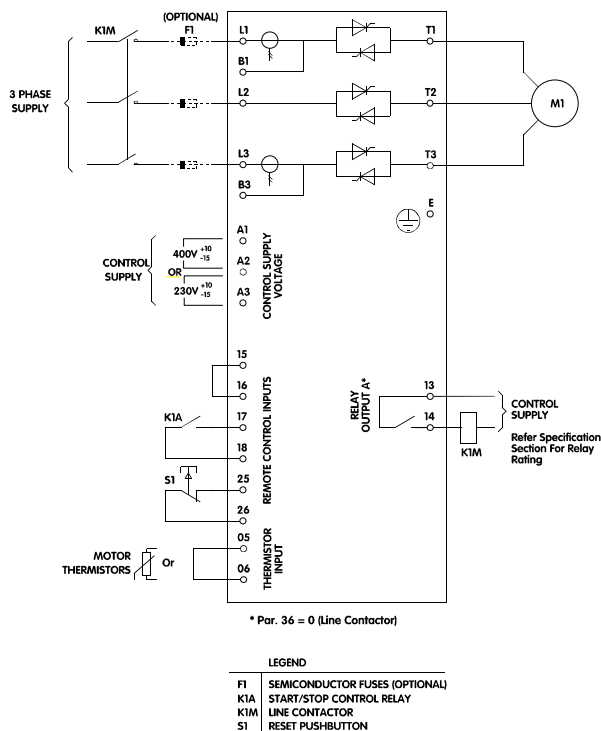

\* Par. 36 = 0 (Line Contactor)

LEGEND	
F1	SEMICONDUCTOR FUSES (OPTIONAL)
KIA	START/STOP CONTROL RELAY
KIM	LINE CONTACTOR
S1	RESET PUSHBUTTON

Notes:

1. The MCD3000 must be in remote mode to function with this circuit. Use the [LOCAL/REMOTE] push button to switch between local and remote modes.
2. Relay Output A must be programmed for the Line Contactor function. Refer Par. 36 *Relay A - Function Assignment*.

Example 3. MCD3000 installed with a bypass contactor and controlled via a remote push button circuit.

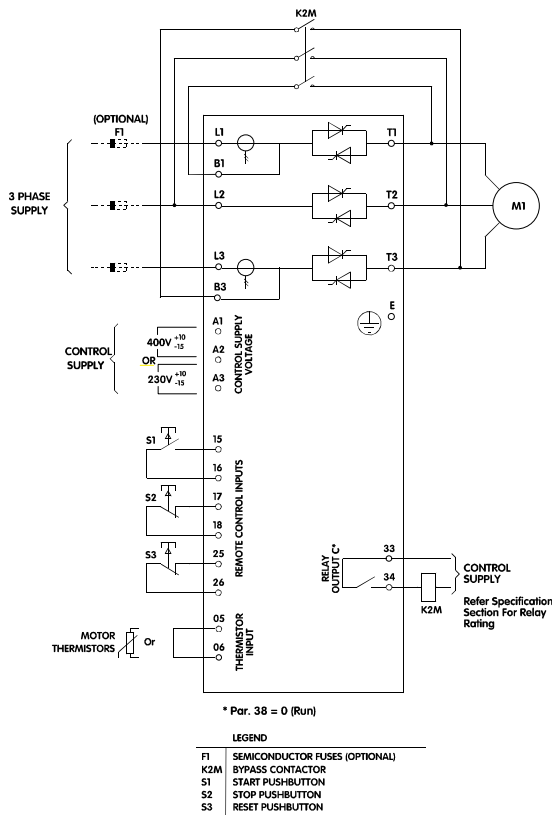

Notes:

- The MCD3000 must be in remote mode to function with this circuit. Use the [LOCAL/REMOTE] push button to switch between local and remote modes.
- Relay Output C must be programmed for the Run function. Refer Par. 38 *Relay C - Function Assignment*.

Example 4. MCD3000 controlled by remote 3 wire push button circuit.

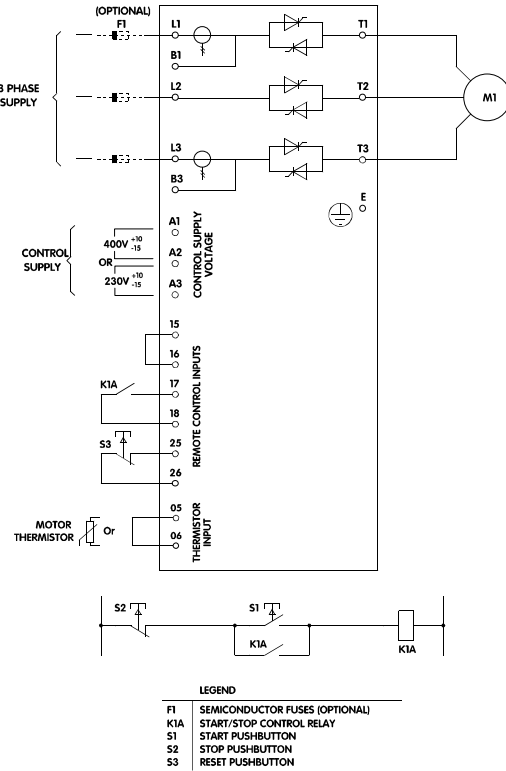

Notes:

- The MCD3000 must be in remote mode to function with this circuit. Use the [LOCAL/REMOTE] push button to switch between local and remote modes.

### Serial communications

The MCD3000 has a **non-isolated** RS485 serial communications link. The serial link can be used to;

- Control MCD3000 operation
- Query MCD3000 status and operating data
- Read (download) MCD3000 parameter settings
- Program (upload) MCD3000 parameters

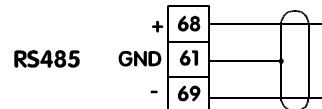

### ATTENTION

Communications cabling should not be located within 300mm of power cabling.

Where this cannot be avoided consideration should be given to providing magnetic shielding to reduce induced common mode voltages.

Data transmitted to and from the MCD3000 must be in 8 bit ASCII, no parity, 1 stop bit.

The MCD3000 can be programmed to trip if the RS485 link fails. This is done by setting Par. 24 *Serial Communications - RS485 Time Out*.

Baud rate is set by Par. 22 *Serial Communication - Baud Rate*.

The starter address is assigned using Par. 23 *Serial Communications - Satellite Address*.



**ATTENTION**

Slave address must be two digit, addresses less than 10 must have a leading zero (0).



**ATTENTION**

If no MCD3000 starter is configured to the specific slave address, no response will be received by the host.



**ATTENTION**

The MCD3000 may take up to 250ms to respond. The host software timeout should be set accordingly.



**ATTENTION**

The satellite address and baud rate may also be altered through the serial interface. Behaviour of the serial interface will not be affected by such parameter changes until the current Serial Programming mode session is terminated by the master. The serial master application must ensure that altering these parameters does not cause communication problems.

The details of the message fragments used in communicating with the MCD3000 are shown in the table below. The message fragments may be assembled into complete messages as described in the sections that follow.

Message Fragment Type	ASCII Character String or (Hexidecimal Character String)
Send Address	EOT [nn] [lrc] ENQ or (04h [nn] [lrc] 05h)
Send Command	
Send Request	STX [ccc] [lrc] ETX or (02h [ccc] [lrc] 03h)
Read Parameters	
Write Parameters	
Receive Data	STX [dddd] [lrc] ETX or (02h [dddd] [lrc] 03h)
Receive Status	STX [ssss] [lrc] ETX or (02h [ssss] [lrc] 03h)
Parameter Number	DC1 [pppp] [lrc] ETX (011h [pppp] [lrc] 03h)
Parameter Value	DC2 [vvvv] [lrc] ETX (012h [vvvv] [lrc] 03h)

Message Fragment Type	ASCII Character String or (Hexidecimal Character String)
ACK	ACK or (06h)
NAK	NAK or (15h)
ERR	BEL (07h)

- nn = two byte ASCII number representing the soft starter address where each decimal digit is represented by n.
- lrc = two byte longitudinal redundancy check in hexadecimal.
- ccc = three byte ASCII command number where each character is represented by a c.
- dddd = four byte ASCII number representing the current or temperature data where each decimal digit is represented by d.
- ssss= four byte ASCII number. The first two bytes are ASCII zero. The last two bytes represent the nibbles of a single byte of status data in hexadecimal.
- pppp = four byte ASCII number representing the parameter number where each decimal digit is represented by p.
- vvvv = four byte ASCII number representing the parameter value where each decimal digit is represented by v.

**Serial communications - commands**

Commands can be sent to the MCD3000 using the following format;

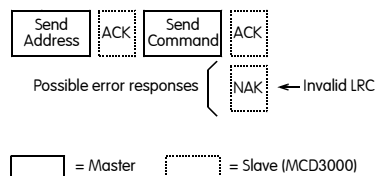

Command	ASCII	Comment
Start	B10	Initiates a start.
Stop	B12	Initiates a stop
Reset	B14	Resets a trip state
Coast to stop	B16	Initiates an immediate removal of voltage from the motor. Any soft stop or D.C.Brake settings are ignored.

**Serial communications – status retrieval**

Starter status can be retrieved from the MCD3000 using the following format;

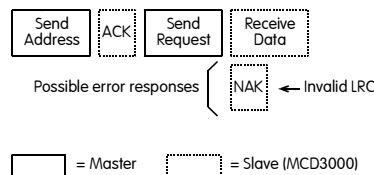
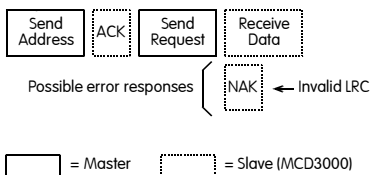

Request	ASCII	Bit No.	Receive Data (ssss)
Status	C10	Requests the configuration status of the MCD3000. (Positive logic 1 = true)	
		Status.0	Unallocated
		Status.1	Unallocated
		Status.2	Unallocated
		Status.3	Positive phase rotation
		Status.4	Soft stopping
		Status.5	Unallocated
		Status.6	60Hz operation
Status_1	C12	Requests the operational status of the MCD3000. (Negative logic 0 = true)	
		NOT Status._1.0	Power On
		NOT Status._1.1	Output On
		NOT Status._1.2	Run
		NOT Status._1.3	Overload
		NOT Status._1.4	Restart delay
		NOT Status._1.5	Unallocated
		NOT Status._1.6	Unallocated
Version	C16	RS485 protocol version number.	
Trip Code	C18	Requests the trip status of the MCD3000. 255= No Trip 0= Shorted SCR trip 1= Excess start time trip 2= Overcurrent trip 3= Motor thermistor trip 4= Phase imbalance trip 5= Supply frequency trip 6= Phase rotation trip 7= Instantaneous overload trip 8= Power circuit fault 9= Undercurrent trip 10= Starter overtemperature trip	

Request	ASCII	Receive Data (dddd)
Current	D10	Requests motor current. The data is 4 byte decimal ASCII. Minimum value 0000, Maximum value 9999 Amps.
Temperature	D12	Requests the calculated value of the motor thermal model as a % of Motor Thermal Capacity. The data is 4 byte decimal ASCII. Minimum value 0000%. Trip point 0105%.

**Serial communications – downloading parameter settings from the MCD3000**

Parameter settings may be downloaded from the MCD3000 at any time using the following format;

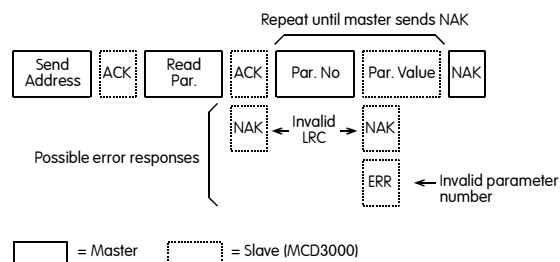

Read Parameters	ASCII	Comment
Download Parameters	P10	Readies MCD3000 to download parameter values.

**Serial communications – uploading parameter settings to the MCD3000**

Parameter adjustments may be uploaded to the MCD3000 only when it is in the off state i.e. not starting, running, stopping or tripped. Use the following format to upload parameters;

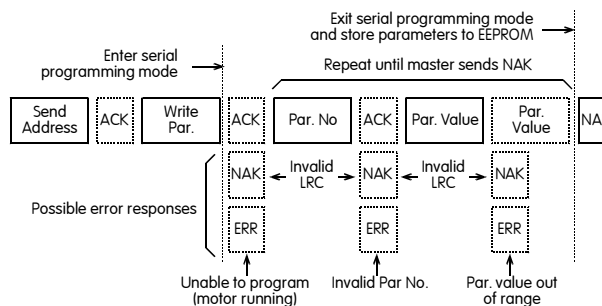

**Serial communications –data retrieval**

Data can be retrieved from the MCD3000 using the following format;

Write Parameters	ASCII	Comment
Upload Parameters	P12	Readies the MCD3000 for uploading of parameter values

When the MCD3000 receives a Upload Parameters command it enters the Serial Programming mode. When in the Serial Programming mode the MCD3000 local push buttons and remote inputs are inoperative, the serial start command is unavailable and MCD3000 numeric display flashes the letters 'SP'.

When the Upload Parameters command is terminated by the master or with an error or with a timeout, the parameters are written to the EEPROM and the MCD3000 exits the Serial Programming mode.

**ATTENTION**

The Serial Programming mode will timeout in 500ms if there has been no serial activity.

**ATTENTION**

The following parameters may not be adjusted, Par 43, 44, 45, 46 & 49. If values for these parameters are uploaded to the MCD3000 there will be no effect and no error generated.

**Serial communications – calculating the check sum (LRC)**

Each command string sent to and from the MCD3000 includes a check sum. The form used is the Longitudinal Redundancy Check (LRC) in ASCII hex. This is an 8-bit binary number represented and transmitted as two ASCII hexadecimal characters.

To calculate LRC:

1. Sum all ASCII bytes
2. Mod 256
3. 2's complement
4. ASCII convert

For example Command String (Start);

```
ASCII STX B 1 0
or 02h 42h 31h 30h
```

ASCII	Hex	Binary	
STX	02h	0000 0010	
B	42h	0100 0010	
1	31h	0011 0001	
0	30h	0011 0000	
	A5h	1010 0101	SUM (1)
	A5h	1010 0101	MOD 256 (2)
	5Ah	0101 1010	1's COMPLEMENT
	01h	0101 1011	+ 1 =
	5Bh	0101 1011	2's COMPLEMENT (3)
ASCII	5	B	ASCII CONVERT (4)
or	35h	42h	LRC CHECKSUM

The complete command string becomes

```
ASCII STX B 1 0 5 B ETX
or 02h 42h 31h 30h 35h 42h 03h
```

To verify a received message containing an LRC;

1. Convert last two bytes of message from ASCII to binary.
2. Left shift 2<sup>nd</sup> to last byte 4 bits.
3. Add to last byte to get binary LRC.
4. Remove last two bytes from message.
5. Add remaining bytes of message.
6. Add binary LRC.
7. Round to one byte.
8. The result should be zero.

Response or status bytes are sent from the MCD3000 as an ASCII string.

```
STX [d1]h [d2]h [d3]h [d4]h LRC1 LRC2 ETX
d1 = 30h
d2 = 30h
d3 = 30h plus upper nibble of status byte right
shifted by four binary places.
d4 = 30h plus lower nibble of status byte.
```

For example status byte = 1Fh, response is

```
STX 30h 30h 31h 46h LRC1 LRC2 ETX
```

**■ Programming**

Number	Parameter Name
1	Motor FLC
2	Current Limit
3	Current Ramp - Initial Current
4	Current Ramp - Ramp Time
5	Soft Stop Ramp Time
6	Motor Thermal Capacity
7	Phase Imbalance Sensitivity
8	Undercurrent Trip Point
9	Instantaneous Overload Trip Point
10	Excess Start Time Protection
11	Phase Rotation Protection
12	Phase Imbalance Protection Delay
13	Undercurrent Protection Delay
14	Instantaneous Overload Protection Delay
15	Restart Delay
16	Torque Enhancement
17	Soft Stop Profile
18	D.C.Brake - Brake Time
19	D.C.Brake - Brake Torque
20	Local / Remote Mode
21	Current Gain
22	Serial Communication - Baud Rate
23	Serial Communication - Satellite Address
24	Serial Communication - RS485 Time Out
25	Motor FLC <sup>1)</sup>
26	Current Limit <sup>1)</sup>
27	Current Ramp - Initial Current <sup>1)</sup>
28	Current Ramp - Ramp Time <sup>1)</sup>
29	Soft Stop Ramp Time <sup>1)</sup>
30	Motor Thermal Capacity <sup>1)</sup>
31	Phase Imbalance Sensitivity <sup>1)</sup>
32	Undercurrent Trip Point <sup>1)</sup>
33	Instantaneous Overload Trip Point <sup>1)</sup>
34	Low Current Flag Set Point
35	High Current Flag Set Point
36	Relay A - Function Assignment
37	Relay B - Function Assignment
38	Relay C - Function Assignment
39	Automatic Reset - Trip Types
40	Automatic Reset - Number Of Resets
41	Automatic Reset - Reset Delay Group 1&2
42	Automatic Reset - Reset Delay Group 3
45	Trip Log
46	Password
47	Change Password
48	Parameter Lock
49	Load Default Parameter Settings
50	Under Frequency Protection Delay

Number	Parameter Name
51	Phase Imbalance Protection Enable
52	Undercurrent Protection Enable
53	Expanded Supply Frequency Window

<sup>1)</sup>Secondary Parameter Set adjustments

★ = factory setting

**■ Programming procedure**

Parameter adjustments are made using the Local Control Panel. **Adjustments can only be made while the MCD3000 is stopped.** When the MCD3000 is in programming mode the three LEDs to the right of the numeric display are illuminated.

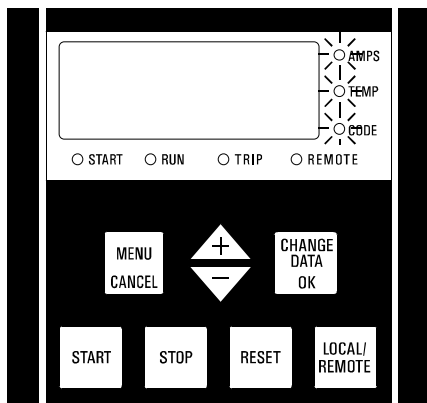

To adjust parameters do the following:

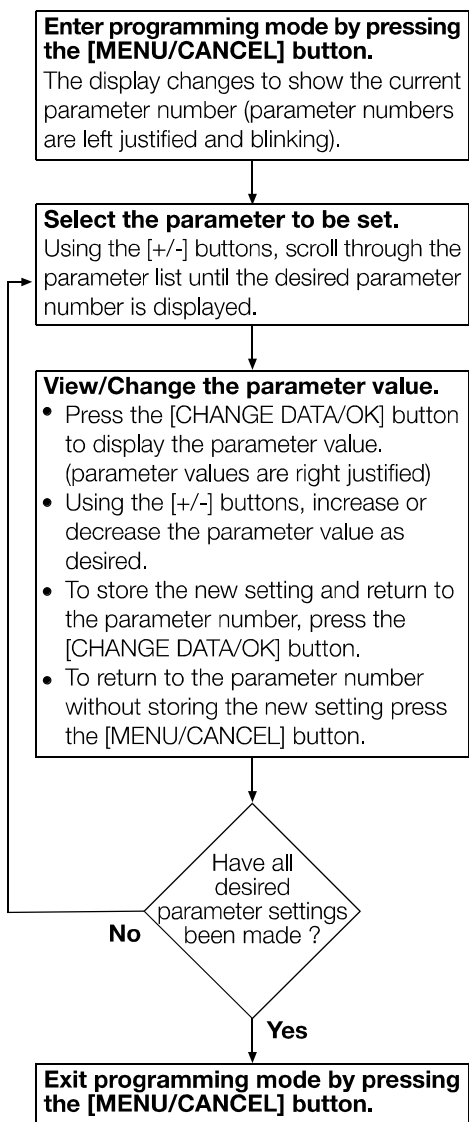

★ = factory setting

**■ Programmable functions**

**1 Motor FLC**

**Value:**  
(Depends On Model) Amps ★ Depends on Model

**Function:**  
Calibrates the MCD3000 for the Full Load Current of the motor.

**Description of choice:**  
Set according to motor nameplate Full Load Current.

**2 Current Limit**

**Value:**  
100% - 550% Motor FLC ★ 350%

**Function:**  
Sets the desired starting current limit.

**Description of choice:**  
The current limit should be set so that the motor accelerates easily to full speed.

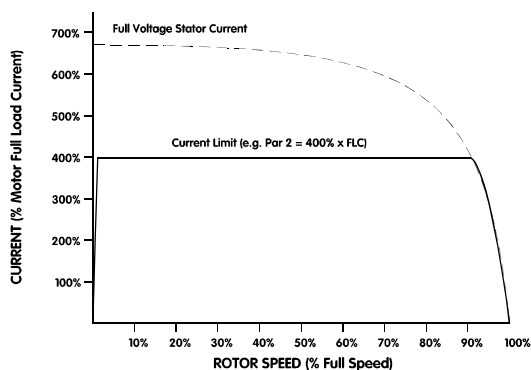

**ATTENTION**  
Start current must be great enough to allow the motor to produce sufficient torque to accelerate the connected load. The minimum current required to do this is dependent on motor design and load torque requirements.

**3 Current Ramp - Initial Current**

**Value:**  
10% - 550% Motor FLC ★ 350%

**Function:**  
Sets the initial starting current for the Current Ramp start mode. See also parameter 4.



**Description of choice:**

See parameter 4.

**4 Current Ramp - Ramp Time**
**Value:**

1 - 30 seconds ★ 1 second

**Function:**

Sets the ramp time for the Current Ramp start mode.

**Description of choice:**

The Current Ramp start mode modifies the Current Limit start mode by adding an extended ramp.

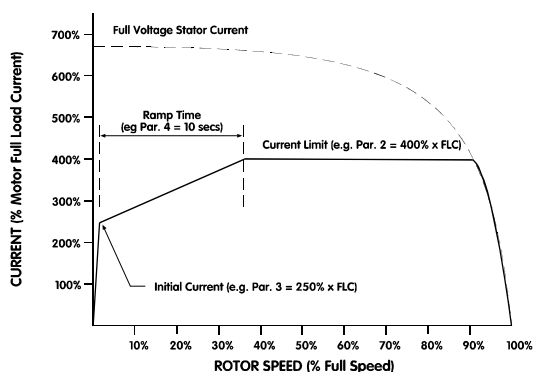

Typically the Current Ramp start mode would be used in two circumstances.

1. For applications where start conditions vary between starts the Current Ramp mode provides an optimum soft start irrespective of motor loading e.g. A conveyor that may start loaded or unloaded.  
In this case make the following settings.
  - Set Parameter 2 *Current Limit* so that the motor can accelerate to full speed when fully loaded.
  - Set Parameter 3 *Current Ramp - Initial Current* so that the motor can accelerate when unloaded.
  - Set Parameter 4 *Current Ramp - Ramp Time* according to the desired start performance. (Very short ramp time settings will result in higher than necessary start current for unloaded starts. Very long ramp time settings may cause starting delays for loaded starts).
2. On generator set supplies where a gradual increase in current is required to allow greater time for the generator set to respond to the increased loading.  
In this case make the following settings.
  - Set Parameter 2 *Current Limit* as desired.

- Set Parameter 3 *Current Ramp - Initial Current* to a lower level than the *Current Limit*.
- Set Parameter 4 *Current Ramp - Ramp Time* to achieve the desired gradual draw of start current.

**5 Soft Stop Ramp Time**
**Value:**

0 - 100 seconds ★ 0 seconds (Off)

**Function:**

Sets the time of the soft stop ramp. The soft stop function extends motor deceleration time by ramping down voltage supplied to the motor when a stop is initiated.

**Description of choice:**

Set the ramp time to optimise stopping characteristics for the load.

The MCD3000 soft stop function has two modes, standard and enhanced pump control. The enhanced pump control mode can offer superior performance in some pumping applications. Refer Par. 17 *Soft Stop Profile*.

**ATTENTION**

The MCD3000 soft stop function automatically determines the step-down voltage setting, no user adjustment is required.

**ATTENTION**

The Soft Stop and D.C.Brake functions cannot be used together. Setting a soft stop ramp time greater than 0 seconds causes Par. 18 *D.C.Brake - Brake Time* to be set to 0 seconds and Par. 38 *Relay C - Function Assignment* to be set to OFF.

**6 Motor Thermal Capacity**
**Value:**

5 - 120 seconds ★ 10 seconds

**Function:**

Calibrates the MCD3000 motor thermal model for the connected motors thermal capacity. The Motor Thermal Capacity is defined as the length of time the motor can sustain Direct-On-Line current.

**Description of choice:**

The factory setting is adequate for most applications. When setting the Motor Thermal Capacity two approaches can be taken.

★ = factory setting

- Set according to the Motor DOL time as shown on the motor data sheet. This makes the full thermal capacity of the connected motor available for use. The motor will be allowed to operate up to its maximum capability during start and when subjected to operational overloads. This is ideal when starting high inertia loads or for applications such as Bandsaws that must ride through high operating overloads.

**ATTENTION**

The MCD3000 assumes Direct-On-Line current to be 600% of motor Full Load

Current. Actual motor DOL current can be accounted for by using the following formula to calculate the value of the Motor Thermal Capacity setting.

$$\text{MTC (Par. 6)} = \left( \frac{\text{Motor Locked Rotor Current (\%)}}{600\%} \right)^2 \times \text{Motor DOL Time}$$

- Set according to load requirements. While the Motor Thermal Capacity can safely be set according to the motor's published DOL time limit, some load types do not need this capacity for starting or riding through overloads while running. In such circumstances setting the Motor Thermal Capacity based on what the load requires will provide an earlier warning of abnormal operation. To set the Motor Thermal Capacity according to load requirement, set MCD3000 display to read motor temperature, run the load, stop and restart the load while monitoring the calculated motor temperature. The Motor Thermal Capacity setting can be reduced until the temperature at the end of a restart is approximately 80%.

**7 Phase Imbalance Sensitivity**
**Value:**

1 - 10 ★ 5 (Normal Sensitivity)

- 1 - 4 = Increased sensitivity
- 5 = Normal sensitivity
- 6 - 10 = Reduced sensitivity

**Function:**

Sets the sensitivity of the imbalance protection.

**Description of choice:**

Adjust the trip point to accommodate the tolerated phase imbalance. The factory setting is normally acceptable but may have to be adjusted to accommodate individual site variations.

Reaction time of the phase imbalance protection can also be adjusted. Refer Par. 12 *Phase Imbalance Protection Delay*.

**ATTENTION**

The phase imbalance trip point is desensitised by 50% during starting and stopping.

**8 Undercurrent Trip Point**
**Value:**

15% - 100% Motor FLC ★ 20 %

**Function:**

Sets the minimum allowable running current.

**Description of choice:**

Where it is desired to stop motor operation on detection of an abnormally low current, set the Undercurrent trip point above the motor magnetising current and below the normal running current. To defeat the Undercurrent protection function, set the trip point below the motor's magnetising current. Typically < 25%. Reaction time of the Undercurrent protection can also be adjusted. Refer Par. 13 *Undercurrent Protection Delay*. Undercurrent protection is disabled during starting and stopping.

**9 Instantaneous Overload Trip Point**
**Value:**

80% - 550% Motor FLC ★ 400%

**Function:**

Sets the trip point for the Instantaneous Overload protection.

**Description of choice:**

The instantaneous overload trip point should be set to trip the motor when it begins to stall. Reaction time of the instantaneous overload protection can also be adjusted. Refer Par. 14 *Instantaneous Overload Protection Delay*. Instantaneous Overload protection is disabled during starting and stopping.

**10 Excess Start Time Protection**
**Value:**

0 - 255 seconds ★ 20 seconds

★ = factory setting

**Function:**

Sets the maximum allowable start time.

**Description of choice:**

Set for a period slightly longer than the normal motor starting time. The MCD3000 will then trip if the start time exceeds normal. This provides early indication that the application conditions have changed or that the motor has stalled. It can also protect the soft starter from being operated outside its rated start capability.

A setting of 0 disables this protection.

**ATTENTION**

Ensure the Excess Start Time protection setting is within the MCD3000 rated capability.

**11 Phase Rotation Protection**
**Value:**

0 - 2 ★ 0 (Off)

0 = Off (Forward & Reverse rotation permitted)

1 = Forward Rotation Only

2 = Reverse Rotation Only

**Function:**

Sets the allowable phase rotation sequence of the incoming supply.

**Description of choice:**

The MCD3000 is itself phase rotation insensitive. This function allows motor rotation to be limited to one direction only. Set the protection according to application requirements.

**12 Phase Imbalance Protection Delay**
**Value:**

3 - 254 seconds ★ 3 seconds

**Function:**

Delays tripping on detection of a phase imbalance greater than allowed by the Phase Imbalance Sensitivity setting. (Par. 7 & Par. 31)

**Description of choice:**

Set to avoid unnecessary tripping due to temporary phase imbalances.

**13 Undercurrent Protection Delay**

★ = factory setting

AMB00000 Rev. G

**Value:**

0 - 60 seconds ★ 5 seconds

**Function:**

Delays tripping on detection of a motor current lower than the programmed Undercurrent Trip Point. (Par. 8 & Par. 32)

**Description of choice:**

Set to avoid unnecessary tripping due to temporary undercurrent situations.  
Undercurrent protection is disabled during starting and stopping.

**14 Instantaneous Overload Protection Delay**
**Value:**

0 - 60 seconds ★ 0 seconds

**Function:**

Delays tripping on detection of a motor current higher than the programmed Instantaneous Overload Trip Point. (Par. 9 & Par. 33)

**Description of choice:**

Set to avoid unnecessary tripping due to temporary high overload situations.

**15 Restart Delay**
**Value:**

0 - 254 Units ★ 1 Unit (10 seconds)

1 Unit = 10 seconds

**Function:**

Sets the minimum time between the end of a stop and the beginning of the next start.

**Description of choice:**

Set according to process requirements. A setting of zero achieves the minimum restart delay of 1 second). During the Restart Delay period the LED to the right of the MCD3000 numeric display will flash, indicating the motor cannot be started.

**16 Torque Enhancement**
**Value:**

0 - 3 ★ 0 (Off)

0 = Off

- 1 = Torque boost
- 2 = Torque control
- 3 = Torque boost & torque control

**Function:**

Activates the torque enhancement functions.

**Description of choice:**

Torque boost provides extra torque at the beginning of a start. Torque boost can be used for loads that require high torque to breakaway but then accelerate freely with lower torque.



**ATTENTION**

Torque boost results in a fast application of torque. Ensure that the driven load and drive chain can handle DOL start torque characteristics.

Torque control provides a more linear application of torque during start.

**17 Soft Stop Profile**

**Value:**

0 - 3 ★ 0 (Standard Mode)

- 0 = Standard mode
- 1 = Pump control (mode 1)
- 2 = Pump control (mode 2)
- 3 = Pump control (mode 3)

**Function:**

Selects between soft stop profiles.

**Description of choice:**

The standard mode is the default soft stop profile and is appropriate for most installations. In standard mode motor deceleration is monitored and soft stop operation is automatically adjusted to optimise performance.

In addition to the standard mode profile three specialised pump control modes are available. These modes provide alternate control algorithms which may deliver superior performance to the standard mode depending upon the individual motor and hydraulic characteristics of the application.

**The D.C.Braking function decreases motor deceleration time by applying a D.C. current to the motor terminals when a stop command is given. This function requires that a contactor (AC1 rated) be wired between output terminals**

★ = factory setting

**T2 & T3 as shown in the electrical schematic below and that the following MCD3000 parameters be adjusted.**

- **Par 18. D.C.Brake - Brake Time**
- **Par 19. D.C.Brake - Brake Torque**
- **Par 38. Relay C - Function Assignment.**



The MCD3000 power modules will be damaged if the D.C.Brake contactor is closed when the D.C.Brake function is not operating. Ensure the D.C.Brake contactor is controlled by Relay Output C and that Par. 38 Relay C - Function Assignment is set for D.C.Braking Contactor Control



The MCD3000 power modules will be damaged if the D.C.Brake contactor is incorrectly connected between T1-T2 or T1-T3.

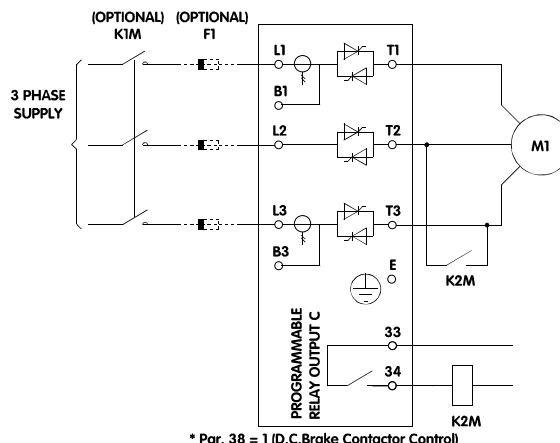

\* Par. 38 = 1 (D.C.Brake Contactor Control)

**LEGEND**

F1	SEMICONDUCTOR FUSES (OPTIONAL)
K1M	LINE CONTACTOR (OPTIONAL)
K2M	DC BRAKING CONTACTOR

**18 D.C.Brake - Brake Time**

**Value:**

0 - 10 seconds ★ 0 seconds (Off)

**Function:**

Sets the time of operation of the D.C. Braking function.

**Description of choice:**

Set as required. A setting of 0 seconds turns the D.C.Brake function Off.



**ATTENTION**

MCD3000 Relay Output C must be programmed for the D.C.Brake Contactor

Control so that the shorting contactor functions correctly. Refer Par. 38 *Relay C - Function Assignment* for adjustment procedure.



### ATTENTION

The D.C.Brake and Soft Stop functions cannot be used together. Setting a D.C.Brake - Brake Time greater than 0 seconds causes Par. 5 *Soft Stop Ramp Time* and Par.29. *Soft Stop Ramp Time (secondary parameter set)* to be set to 0 seconds.



### ATTENTION

During operation of the D.C.Brake function the MCD3000 display shows the letters 'br' as shown below.

br

## 19 D.C.Brake - Brake Torque

### Value:

30% - 100% Braking Torque ★ 30%

### Function:

Sets the D.C.Brake level as a % of maximum braking torque.

### Description of choice:

Set as required.



### ATTENTION

For very high inertia loads more braking torque is available by use of the 'Soft Braking' technique described in the Design Guide section of this manual.

## 20 Local / Remote Mode

### Value:

0 - 3 ★ 0 ([LOCAL/REMOTE] button enabled)

0 = [Local/Remote] push button on MCD3000 enabled all the time.

1 = [Local/Remote] push button on MCD3000 enabled only while motor stopped.

2 = Local control only. (MCD3000 push buttons enabled, remote inputs disabled)

3 = Remote control only. (MCD3000 push buttons disabled, remote inputs enabled)

### Function:

Determines when MCD3000 push buttons and remote control inputs are operative. Also when, and if, the [Local/Remote] push button can be used to switch between local and remote control.

★ = factory setting

### Description of choice:

Set according to desired operational requirements.

## 21 Current Gain

### Value:

85% - 115% ★ 100%

### Function:

Adds a gain to the MCD3000 current monitoring circuits. These circuits are factory calibrated with an accuracy of ±5%. The gain can be used to match the MCD3000 current read out with an external current monitoring system.



### ATTENTION

This adjustment affects all current based functions. e.g. current read-out, motor overload & all other current based protections and current outputs.

### Description of choice:

The gain should be adjusted according to the following formula.

$$\text{Current Gain (Par. 21)} = \frac{\text{Current shown on MCD3000 display}}{\text{Current measured by external device}}$$

$$\text{e.g. } 104\% = \frac{48 \text{ Amps}}{46 \text{ Amps}}$$

## 22 Serial Communications - Baud Rate

### Value:

1 - 5 ★ 4 (9600 baud)

1 = 1200 baud

2 = 2400 baud

3 = 4800 baud

4 = 9600 baud

5 = 19200 baud

### Function:

Sets the baud rate for serial communications.

### Description of choice:

Set as appropriate.

## 23 Serial Communications - Satellite Address

**Value:**  
1 - 99 ★ 20

**Function:**  
Assigns the MCD3000 an address for serial communications.

**Description of choice:**  
Set a unique address number as appropriate.

**24 Serial Communications - RS485 Time Out**

**Value:**  
0 - 100 seconds ★ 0 seconds (Off)

**Function:**  
Sets the maximum allowable period of RS485 inactivity.

**Description of choice:**  
Set this parameter if it is required that a trip should occur in the event of a failure of RS485 communications with the MCD3000. A setting of 0 seconds allows the MCD3000 to continue operating without regular RS485 activity.

**ATTENTION**  
In the event of a RS485 Time Out trip the MCD3000 cannot be reset until the RS485 communication is resumed. If the RS485 communications cannot be immediately re-established and temporary manual control is required, Par 24 *Serial Communications - RS485 Time Out* must be set to 0 seconds.

**The MCD3000 includes two motor operating parameter sets. Parameters 25 - 33 make up the secondary parameter set and replicate the primary parameter set, Parameters 1 - 9. Refer to the Operation section of this manual for detail on enabling the secondary parameter set.**

**25 Motor FLC (Secondary Parameter Set)**

**Value:**  
(Depends On Model)Amps ★ Depends on Model

See Par. 1 for Function & Description of choice.

**26 Current Limit (Secondary Parameter Set)**

**Value:**  
100% - 550% Motor FLC ★ 350 %

See Par. 2 for Function & Description of choice.

**27 Current Ramp - Initial Current (Secondary Parameter Set)**

**Value:**  
10% - 550% Motor FLC ★ 350%

See Par. 3 for Function & Description of choice.

**28 Current Ramp - Ramp Time (Secondary Parameter Set)**

**Value:**  
1 - 30 seconds ★ 1 second

See Par. 4 for Function & Description of choice.

**29 Soft Stop Ramp Time (Secondary Parameter Set)**

**Value:**  
0 - 100 seconds ★ 0 seconds (Off)

See Par. 5 for Function & Description of choice.

**30 Motor Thermal Capacity (Secondary Parameter Set)**

**Value:**  
5 - 120 seconds ★ 10 seconds

See Par. 6 for Function & Description of choice.

**31 Phase Imbalance Sensitivity (Secondary Parameter Set)**

**Value:**  
1 - 10 ★ 5 (Normal Sensitivity)

- 1 - 4 = Increased sensitivity
- 5 = Normal sensitivity
- 6 - 10 = Reduced sensitivity

See Par. 7 for Function & Description of choice.

**32 Undercurrent Trip Point (Secondary Parameter Set)**

**Value:**  
15% - 100% Motor FLC ★ 20 %

See Par. 8 for Function & Description of choice.

★ = factory setting

**33 Instantaneous Overload Trip Point (Secondary Parameter Set)**
**Value:**

80% - 550% Motor FLC ★ 400%

See Par. 9 for Function &amp; Description of choice.

**34 Low Current Flag Set Point**
**Value:**

1 - 100% Motor FLC ★ 50% Motor FLC

**Function:**

Sets the current at which the Low Current Flag operates. (Low current flags can occur only when the motor is running).

Relay Output B can be programmed to indicate the state of the Low Current Flag. The relay output will change state when motor current is below the set point.

 See Par. 37 for *Relay B - Function Assignment*.

**Description of choice:**

Set as appropriate.

**35 High Current Flag Set Point**
**Value:**

50 - 550% Motor FLC ★ 105% Motor FLC

**Function:**

Sets the current at which the High Current Flag operates. (High current flags can occur only when the motor is running).

Relay Output B can be programmed to indicate the state of the High Current Flag. The relay output will change state when motor current is above the set point.

 See Par. 37 for *Relay B - Function Assignment*.

**Description of choice:**

Set as appropriate.

**36 Relay A - Function Assignment**
**Value:**

0 - 3 ★ 0 (Line contactor)

0 = Line Contactor

1 = Run

2 = High current flag (see Par. 35)

3 = Low current flag (see Par. 34)

**Function:**

Sets the functionality of Relay Output A

**Description of choice:**

Set as required.

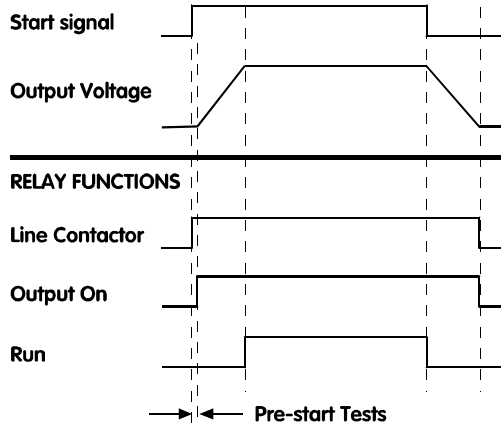
**37 Relay B - Function Assignment**
**Value:**

0 - 4 ★ 0 (Trip)

0 = Trip

1 = Output on

2 = High current flag (see Par. 35)

3 = Low current flag (see Par. 34)

4 = Line contactor

**Function:**

Sets the functionality of Relay Output B

**Description of choice:**

See Par. 36

**38 Relay C - Function Assignment**
**Value:**

0 - 2 ★ 0 (Run)

0 = Run

1 = D.C.Brake Contactor Control

2 = Off (does not operate)

**Function:**

Sets the functionality of Relay Output C

**Description of choice:**

Set to 1 (D.C.Brake Contactor Control) only when using the D.C.Brake function and make this

★ = factory setting

adjustment only after first setting Par. 18 *D.C.Brake - Brake Time*.



### ATTENTION

To reduce the chance of equipment damage through inappropriate adjustment of Relay C functionality the MCD3000 automatically sets this parameter to 2 (Off) in the following instances.

- If a soft stop time is programmed while Par. 38. *Relay C - Function Assignment* is set to 1 (D.C.Brake Contactor Control).
- When Par. 18 *D.C.Brake - Brake Time* is changed to 0 seconds.
- When Par. 18 *D.C.Brake - Brake Time* is changed from 0 seconds.

**The Automatic Reset function enables selected trip types to be automatically reset. Automatic Reset operation is affected by three settings.**

- **Trip Types**
- **Number Of Resets**
- **Reset Delay**



If the start command is still present after a trip state is reset the motor will be restarted. Ensure that personal safety is not at risk from such operation and that all appropriate safety measures have been taken.

### 39 Automatic Reset - Trip Types

#### Value:

0 - 3 ★ 0 (Off)

0 = Off.

1 = Automatically reset Group 1 trips.

2 = Automatically reset Group 1 & 2 trips.

3 = Automatically reset Group 1,2 & 3 trips.

#### Function:

Selects what fault types will be automatically reset.

#### Description of choice:

Three groups of trips can be automatically reset.

Group	Trip Type
1	Phase Imbalance, Phase Loss
2	Undercurrent, Instantaneous Overload
3	Overcurrent, Motor Thermistor

### 40 Automatic Reset - Number Of Resets

★ = factory setting

#### Value:

1 - 5 Resets ★ 1 Reset

#### Function:

Sets the number of times faults will be reset before the trip condition is latched and a manual reset is required.

#### Description of choice:

Set according to the maximum number of resets required.

The MCD3000 reset counter will increment by one when a trip occurs up to the programmed number of resets. A manual reset will then be required.

The reset counter decrements by one (to a minimum of zero) after each successful start/stop cycle.

### 41 Automatic Reset - Reset Delay Group 1 & 2

#### Value:

5 - 999 seconds ★ 5 seconds

#### Function:

Sets the delay before automatic reset of Group 1 and Group 2 trips.

#### Description of choice:

Set as required.

### 42 Automatic Reset - Reset Delay Group 3

#### Value:

5 - 60 minutes ★ 5 minutes

#### Function:

Sets the delay before automatic reset of Group 3 trips.

#### Description of choice:

Set as required.

### 43 Factory Diagnostic Display A

#### Value:

No adjustment

### 44 Factory Diagnostic Display B

#### Value:

No adjustment

### 45 Trip Log

#### Value:



Read Only

★ No setting

### Function:

Displays the Trip Log. The trip log records the cause of the last 8 trip events.

### Description of choice:

Use the [+/-] buttons to scroll through the trip log. Refer to the Fault Procedure section of this manual for a full explanation of the trip log, trip codes and related fault procedures.

## 46 Password

### Value:

0 - 999 ★ 0

### Function:

Entry of the correct password number does two things.

1. If the parameter settings are currently in the Read Only state (Refer Par. 48 *Parameter Lock*) entering the correct password number temporarily enables the Read/Write state allowing parameter settings to be changed. On exit of the programming mode parameters return to the Read Only state.
2. Allows access to parameter numbers 47, 48 & 49. These parameters allow the user to:
  - Change the password number
  - Change the parameter state between Read/Write and Read Only thus providing control over unauthorised changes to program settings.
  - Load the default factory settings.

### Description of choice:

Enter the current password number. If the password number has been lost, contact your Danfoss representative.

## 47 Change Password

### Value:

0 - 999 ★ 0

### Function:

Sets the password number.

### Description of choice:

Set and record the password number as required.

## 48 Parameter Lock

★ = factory setting

### Value:

0 - 1 ★ 0 (Read/Write)

0 = Read/Write

1 = Read Only

### Function:

Enables protection of program settings by restricting Program Mode functionality to Read Only.

### Description of choice:

Set as required.



### ATTENTION

When the parameter lock has been changed from Read/Write to Read Only the new setting only takes effect once the programming mode has been exited.

## 49 Load Default Parameter Values

### Value:

0 - 100 ★ 0

50 = Load default parameter values

### Function:

Resets parameter values to factory default settings.

### Description of choice:

Set as required.

## 50 Under Frequency Protection Delay

### Value:

0 - 60 seconds ★ 0 seconds

### Function:

Delays tripping on detection of a low supply frequency when the motor is running, <48Hz (50Hz supplies), <58Hz (60Hz supplies).



### ATTENTION

If the supply frequency drops below 45Hz (50Hz supplies) or 55Hz (60Hz supplies) the MCD3000 will trip instantly irrespective of the delay setting.

### Description of choice:

Set to allow continued operation during extreme but temporary under frequency conditions.

## 51 Phase Imbalance Protection Enable

**Value:**

 0 – 1 ★ 0 (On)

0 = On

1 = Off

**Function:**

Activates or defeats the phase imbalance protection.

**Description of choice:**

Set as required.

**52 Undercurrent Protection Enable**
**Value:**

 0 – 1 ★ 0 (On)

0 = On

1 = Off

**Function:**

Activates or defeats the undercurrent protection.

**Description of choice:**

Set as required.

**53 Expanded Supply Frequency Window**
**Value:**

 0 – 1 ★ 0

0 = Normal (50Hz window: 48Hz- 52Hz, 60Hz window 58Hz – 62Hz)

1 = Expanded (50Hz window: 47Hz- 52Hz, 60Hz window 57Hz – 62Hz)

**Function:**

Expands the supply frequency window allowed by the MCD3000 by reducing the lower limit by 1 Hz. This expansion accommodates power supplies which suffer long term low frequency situations.

**Description of choice:**

Apply expansion if required.

■ **Operation**

Once the MCD3000 has been installed, wired and programmed according to the instructions earlier in this manual, it can be operated.

■ **Local control panel.**

The Local Control Panel can be used to operate the MCD3000 when in local control mode.

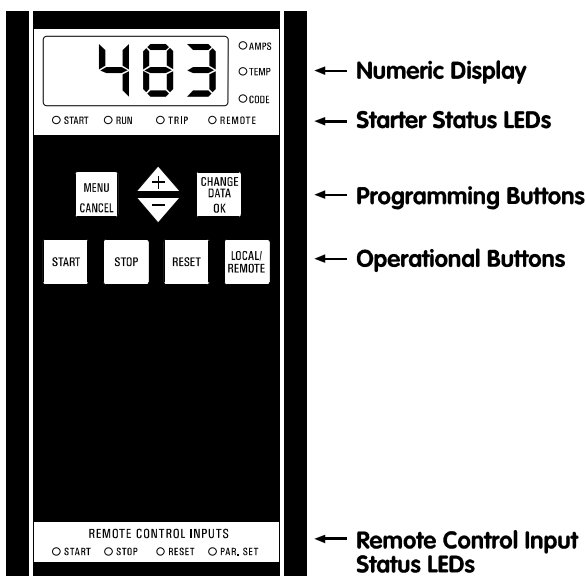

1. **Numeric Display**  
During operation the display can show either motor current (Amps) or motor temperature (%) as calculated by the MCD3000 motor thermal model. The information being displayed is indicated by the LEDs to the right of the display, and can be changed using the [+/-] buttons. In the event of a trip the display shows the trip code. Refer to the Fault Procedure section of this manual.

**ATTENTION**  
If motor current exceeds the maximum current able to be shown on the numeric display, the display will show dashes.

2. **Starter Status LEDs**
  - Start: Voltage is being applied to the motor
  - Run: Full voltage is being applied to the motor.
  - Trip: The starter has tripped.
  - Remote: The MCD3000 is in remote control mode. The local [START],[STOP],[RESET] push buttons are not operative.

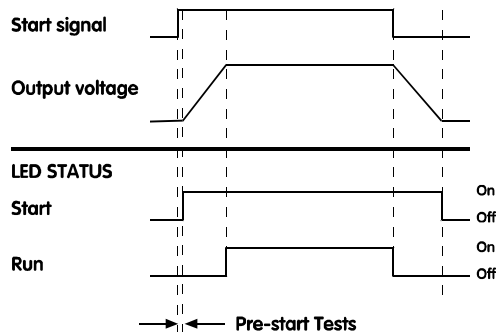

3. **Operational buttons.**  
Can be used to control operation when the MCD3000 is in local mode. Switch between local and remote modes using the [LOCAL/REMOTE] push button.

**ATTENTION**  
Par. 20 Local / Remote Mode can be set to prohibit either local or remote mode operation. If the [LOCAL/REMOTE] button is used in an attempt to switch to a prohibited mode the numeric display will show 'OFF'. Also, operation of the [LOCAL/REMOTE] push button can be restricted to when the motor is stopped. In this case pushing the [LOCAL/REMOTE] push button results in the numeric display showing 'OFF'.

**ATTENTION**  
When control power is applied the MCD3000 may be in either local or remote mode according to the mode it was in when control power was removed. The factory setting is local control.

**ATTENTION**  
Simultaneously pressing the [STOP] and [RESET] buttons causes the MCD3000 to immediately remove voltage from the motor resulting in a coast to stop. Any soft stop or D.C.Brake settings are ignored.

4. **Programming Buttons**  
Refer to the Programming Section of this manual.
5. **Remote Control Input Status LEDs**  
Indicate the state of the circuits connected across the MCD3000 remote control inputs.

**ATTENTION**  
When control power is applied to the MCD3000, all LEDs and Numeric Display segments are illuminated for approximately 1 second to test their operation.

■ **Remote control**

Remote circuits connected to the MCD3000 control inputs can be used to operate the starter when in

remote control mode. Refer to the Installation section of this manual for detail on control wiring options.

■ **Serial communication**

The RS485 serial link can be used to control operation when the starter is either local or remote modes. Programming of the MCD3000 via the serial link is also possible. Refer to the Installation section of this manual for detail on serial communications functions.

■ **Restart delay**

Par. 15 *Restart Delay* sets a minimum time between the end of a stop and the beginning of the next start. During this period the LED to the right of the numeric display will flash, indicating the motor cannot be started.

■ **Secondary parameter set**

The MCD3000 has two motor parameter sets.

- Primary Parameter Set : Par. 1 - 9
- Secondary Parameter Set : Par. 25 - 33

When the MCD3000 is in the off state and is commanded to start, it checks the Par. Set control input. If open circuit the primary parameter set is used. If closed circuit the secondary parameter set is used.

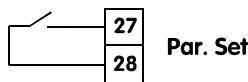

**ATTENTION**

If the start command is given while the MCD3000 is in the process of stopping (Soft stop or D.C.Braking) the MCD3000 restarts without checking the Par. Set control input.

■ **Motor thermal model**

The MCD3000 motor overload protection is an advanced motor thermal model. Motor temperature is continuously calculated by the microprocessor that uses a sophisticated mathematical model to accurately reflect motor heat generation and dissipation during all stages of operation. e.g. Starting, Running, Stopping & Stopped.

Because it operates continuously, the motor thermal model eliminates the need for protection systems such as; Excess Start Time, Limited Starts per hour etc. The state of the motor thermal model can be viewed on the numeric display while the MCD3000 is not in programming mode. Use the [+/-] keys to change the parameter shown on the numeric display.

Motor temperature is shown as a % of maximum temperature. An overload trip occurs at 105%.

■ **Pre-start tests**

On receiving a start command, MCD3000 starters operate the Line Contactor relay output (if programmed) and then perform a series of tests before applying voltage to the motor terminals and operating the Output On relay output (if programmed).

■ **Operation after power loss**

When control and supply voltage is applied to the MCD3000 it will enter either the local or remote mode according to the state it was in when voltage was removed.

If in remote mode, the condition of the remote control inputs is checked and if a start command is present the motor will be started.

If in local mode, the motor will not be restarted until the [START] push button is activated.

**■ General Technical Data**

Mains supply (L1, L2, L3):

Supply voltage MCD3000-T5 .....	3 x 200 VAC ~ 525 VAC
.....	3 x 200 VAC ~ 440 VAC (Inside Delta Connection)
Supply voltage MCD3000-T7 .....	3 x 200 VAC ~ 690VAC
.....	3 x 200 VAC ~ 440 VAC (Inside Delta Connection)
Supply frequency (at start) .....	50HZ (± 2Hz) / 60 Hz (± 2Hz)
Supply frequency (during start) .....	>45Hz (50Hz supply) or >55Hz (60 Hz supply)
Supply frequency (during run) .....	>48Hz (50Hz supply) or >58Hz (60 Hz supply)
Electronics control voltage .....	230 VAC (+10%/-15%) or 400 VAC (+10%/-15%)

Control Inputs

Start (Terminals 15 & 16) .....	Normally Open, Active 24 VDC, 8mA approx.
Stop (Terminals 17 & 18) .....	Normally Closed, Active 24 VDC, 8mA approx.
Reset (Terminals 25 & 26) .....	Normally Closed, Active 24 VDC, 8mA approx.
Parameter Set (Terminals 27 & 28) .....	Normally Open, Active 24 VDC, 8mA approx.

Relay Outputs

Programmable Output A <sup>1)</sup> (Terminals 13 & 14) .....	Normally Open, 5 A @ 250 VAC/360 VA, 5 A @ 30 VDC resistive
Programmable Output B <sup>2)</sup> (Terminals 21, 22 & 24) ....	Changeover, 5 A @ 250 VAC/360 VA, 5 A @ 30 VDC resistive
Output C <sup>3)</sup> (Terminals 33 & 34) .....	Normally Open, , 5 A @ 250 VAC/360 VA, 5 A @ 30 VDC resistive

<sup>1)</sup> Programmable functions: Line contactor, Run, High current flag, Low current flag

<sup>2)</sup> Programmable functions: Tripped, Output on, High current flag, Low current flag, Line contactor

<sup>3)</sup> Programmable functions: Run, D.C.Brake Contactor Control, Off

Environmental

Degree of protection MCD3007 to MCD3132 .....	IP21
Degree of protection MCD3185 to MCD3800 .....	IP20
Operating Temperatures .....	-5°C / +60°C
Rated short-circuit current (with semi-conductor fuses) .....	100kA
Rated insulation voltage (Surges) .....	2 kV line to earth, 1kV line to line
Rated impulse withstand voltage (Fast transients) .....	2 kV
Pollution Degree .....	Pollution Degree 3
Electro static discharge .....	4 kV contact discharge, 8 kV air discharge
Equipment class (EMC) .....	Class A
Radio-frequency electromagnetic field .....	0.15 MHz - 80 MHz: 140dBµV 80 MHz - 1 GHz: 10 V/m

This product has been designed for Class A equipment. Use of the product in domestic environments may cause radio interference, in which case the user may be required to employ additional mitigation methods.

Standards Approvals

C✓ .....	CISPR-11
UL <sup>1</sup> .....	UL508
C-UL <sup>1</sup> .....	CSA 22.2 No. 14
CE .....	IEC 60947-4-2

<sup>1</sup> Requires use of semi-conductor fuses. Excludes models MCD3600~MCD3800

**■ Current Ratings**

<b>Continuous Ratings (Not bypassed) at 40°C Ambient Temperature, &lt; 1000 metres ★</b>						
<b>Model</b>	<b>3.0 x FLC</b>		<b>4.0 x FLC</b>		<b>4.5 x FLC</b>	
	AC53a 3.0-30 : 50-10		AC53a 4.0-20 : 50-10		AC53a 4.5-30 : 50-10	
MCD3007	20A		16A		14A	
MCD3015	34A		28A		25A	
MCD3018	39A		33A		29A	
MCD3022	47A		40A		35A	
MCD3030	68A		54A		48A	
MCD3037	86A		70A		61A	
MCD3045	93A		76A		65A	
MCD3055	121A		100A		86A	
MCD3075	138A		110A		97A	
MCD3090	196A		159A		138A	
MCD3110	231A		188A		163A	
MCD3132	247A		198A		174A	
MCD3185	364A	(546A IDC <sup>1</sup> )	299A	(448A IDC <sup>1</sup> )	255A	(382A IDC <sup>1</sup> )
MCD3220	430A	(645A IDC <sup>1</sup> )	353A	(529A IDC <sup>1</sup> )	302A	(453A IDC <sup>1</sup> )
MCD3300	546A	(819a IDC <sup>1</sup> )	455A	(682A IDC <sup>1</sup> )	383A	(574A IDC <sup>1</sup> )
MCD3315	630A	(945A IDC <sup>1</sup> )	530A	(795A IDC <sup>1</sup> )	442A	(663A IDC <sup>1</sup> )
MCD3400	775A	(1162A IDC <sup>1</sup> )	666A	(999A IDC <sup>1</sup> )	545A	(817A IDC <sup>1</sup> )
MCD3500	897A	(1345A IDC <sup>1</sup> )	782A	(1173A IDC <sup>1</sup> )	632A	(948A IDC <sup>1</sup> )
MCD3600	1153A	(1729a IDC <sup>1</sup> )	958A	(1437A IDC <sup>1</sup> )	826A	(1239A IDC <sup>1</sup> )
MCD3700	1403A	(2104A IDC <sup>1</sup> )	1186A	(1779A IDC <sup>1</sup> )	1013A	(1519A IDC <sup>1</sup> )
MCD3800	1564A	(2346A IDC <sup>1</sup> )	1348A	(2022A IDC <sup>1</sup> )	1139A	(1708A IDC <sup>1</sup> )

<b>Bypassed Ratings at 40°C Ambient Temperature, &lt; 1000 metres ★</b>						
<b>Model</b>	<b>3.0 x FLC</b>		<b>4.0 x FLC</b>		<b>4.5 x FLC</b>	
	AC53b 3.0-30 : 330		AC53b 4.0-20 : 340		AC53b 4.5-30 : 330	
MCD3007	21A		18A		15A	
MCD3015	35A		32A		27A	
MCD3018	41A		39A		33A	
MCD3022	50A		49A		40A	
MCD3030	69A		57A		49A	
MCD3037	88A		73A		63A	
MCD3045	96A		81A		69A	
MCD3055	125A		107A		91A	
MCD3075	141A		115A		100A	
MCD3090	202A		168A		144A	
MCD3110	238A		199A		171A	
MCD3132	254A		206A		179A	
MCD3185	364A	(546A IDC <sup>1</sup> )	307A	(460A IDC <sup>1</sup> )	261A	(391A IDC <sup>1</sup> )
MCD3220	430A	(645A IDC <sup>1</sup> )	362A	(543A IDC <sup>1</sup> )	307A	(460A IDC <sup>1</sup> )
MCD3300	546A	(819A IDC <sup>1</sup> )	470A	(705A IDC <sup>1</sup> )	392A	(588A IDC <sup>1</sup> )
MCD3315	630A	(945A IDC <sup>1</sup> )	551A	(826A IDC <sup>1</sup> )	455A	(682A IDC <sup>1</sup> )
MCD3400	775A	(1662A IDC <sup>1</sup> )	702A	(1053 IDC <sup>1</sup> )	566A	(849A IDC <sup>1</sup> )
MCD3500	897A	(1345A IDC <sup>1</sup> )	833A	(1249A IDC <sup>1</sup> )	661A	(991A IDC <sup>1</sup> )
MCD3600	1153A	(1729A IDC <sup>1</sup> )	1049A	(1573A IDC <sup>1</sup> )	887A	(1330A IDC <sup>1</sup> )
MCD3700	1403A	(2104A IDC <sup>1</sup> )	1328A	(1992A IDC <sup>1</sup> )	1106A	(1659A IDC <sup>1</sup> )
MCD3800	1570A	(2355A IDC <sup>1</sup> )	1534A	(2301A IDC <sup>1</sup> )	1257A	(1885A IDC <sup>1</sup> )

<sup>1</sup>. Inside delta connection

★ For ambient temperature or altitude conditions beyond those listed contact Danfoss.

**■ Power Termination Details**

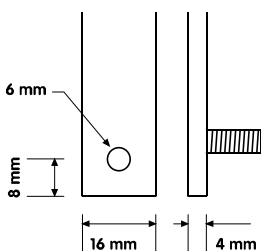
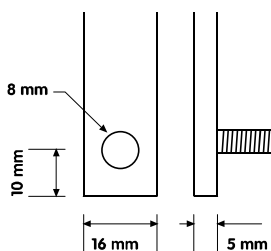
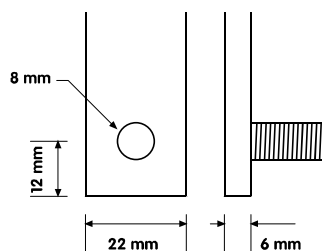
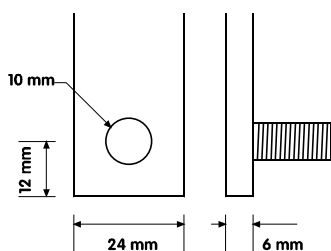
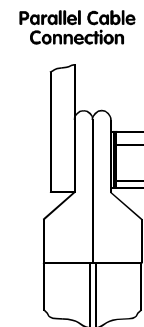
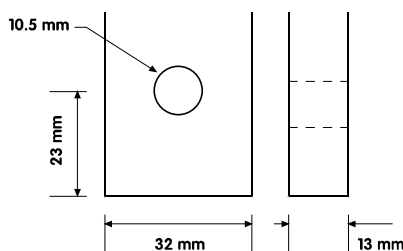
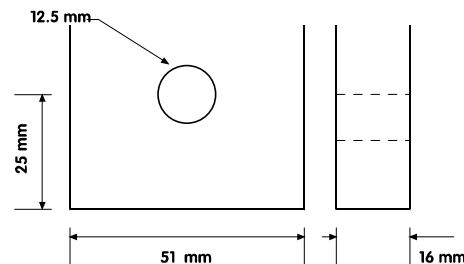
**MCD3007 ~ MCD3055**  
 (3.5 NM, 2.6 FT-LBS)

**MCD3075**  
 (8.5 NM, 6.3 FT-LBS)

**MCD3090 ~ MCD3110**  
 (8.5 NM, 6.3 FT-LBS)

**MCD3132**  
 (17 NM, 12.5 FT-LBS)

**MCD3185 ~ MCD3500**

**MCD3600 ~ MCD3800**
**■ Semiconductor Fuses**

Semiconductor fuses listed below are manufactured by Bussman and should be ordered directly from Bussman or their local supplier. Instruction for selection of alternate semi-conductor fuses is available from Danfoss.

Model	Bussmann Fuse 400V	Bussmann Fuse 525V	Bussmann Fuse 690V	I2t
MCD3007	170M1315	170M1314	170M1314	1150
MCD3015	170M1318	170M1317	170M1317	8000
MCD3018	170M1319	170M1317	170M1317	10500
MCD3022	170M1319	170M1318	170M1318	15000
MCD3030	170M1319	170M1319	170M2616	15000
MCD3037	170M1322	170M1320	170M1320	51200
MCD3045	170M1322	170M1321	170M1321	80000
MCD3055	170M1322	170M1322	170M1322	97000
MCD3075	170M2621	170M1322	170M1322	97000
MCD3090	170M3021	170M3021	170M3020	245000
MCD3110	170M3023	170M3023	170M3023	414000
MCD3132	170M3023	170M3023	170M3023	414000
MCD3185	170M6011	170M5012	170M4145	238000
MCD3220	170M6012	170M4016	170M6011	320000
MCD3300	170M6014	170M6014	170M4018	781000
MCD3315	170M5017	170M6015	170M6014	1200000
MCD3400	170M6019	170M6018	170M6017	2532000
MCD3500	170M6021	170M6020	170M6151	4500000
MCD3600	170M6021	170M6020	170M6151	4500000
MCD3700	170M6021	170M6021	2 x 170M5018	6480000
MCD3800	170M6021	170M6021	2 x 170M5018	13000000

**■ Dimensions / Weights**
**IP 21 Enclosure**

MCD Model	A	B	C	a	b	Weight (kg)
	mm (inches)	mm (inches)	mm (inches)	mm (inches)	mm (inches)	
MCD3007	530 (20.87)	132 (5.20)	270 (10.63)	512 (20.16)	90 (3.54)	11
MCD3015	530 (20.87)	132 (5.20)	270 (10.63)	512 (20.16)	90 (3.54)	11
MCD3018	530 (20.87)	132 (5.20)	270 (10.63)	512 (20.16)	90 (3.54)	11
MCD3022	530 (20.87)	132 (5.20)	270 (10.63)	512 (20.16)	90 (3.54)	11
MCD3030	530 (20.87)	132 (5.20)	270 (10.63)	512 (20.16)	90 (3.54)	11.5
MCD3037	530 (20.87)	132 (5.20)	270 (10.63)	512 (20.16)	90 (3.54)	11.5
MCD3045	530 (20.87)	132 (5.20)	270 (10.63)	512 (20.16)	90 (3.54)	11.5
MCD3055	530 (20.87)	132 (5.20)	270 (10.63)	512 (20.16)	90 (3.54)	11.5
MCD3075	530 (20.87)	264 (10.40)	270 (10.63)	512 (20.16)	222 (8.74)	19.5
MCD3090	530 (20.87)	264 (10.40)	270 (10.63)	512 (20.16)	222 (8.74)	19.5
MCD3110	530 (20.87)	264 (10.40)	270 (10.63)	512 (20.16)	222 (8.74)	19.5
MCD3132	530 (20.87)	396 (15.60)	270 (10.63)	512 (20.16)	354 (13.94)	27

**IP 20 Enclosure**

MCD Model	A	B	C	a	b	Weight (kg)
	mm (inches)	mm (inches)	mm (inches)	mm (inches)	mm (inches)	
MCD3185	850 (33.46)	430 (16.93)	280 (11.02)	828 (32.59)	370 (14.57)	49.5
MCD3220	850 (33.46)	430 (16.93)	280 (11.02)	828 (32.59)	370 (14.57)	49.5
MCD3300	850 (33.46)	430 (16.93)	280 (11.02)	828 (32.59)	370 (14.57)	49.5
MCD3315	850 (33.46)	430 (16.93)	280 (11.02)	828 (32.59)	370 (14.57)	49.5
MCD3400	850 (33.46)	430 (16.93)	280 (11.02)	828 (32.59)	370 (14.57)	49.5
MCD3500	850 (33.46)	430 (16.93)	280 (11.02)	828 (32.59)	370 (14.57)	49.5
MCD3600	1000 (39.37)	560 (22.05)	315 (12.40)	978 (38.49)	500 (19.69)	105
MCD3700	1000 (39.37)	560 (22.05)	315 (12.40)	978 (38.49)	500 (19.69)	105
MCD3800	1000 (39.37)	560 (22.05)	315 (12.40)	978 (38.49)	500 (19.69)	105

MCD3007 ~ MCD3132

MCD3185 ~ MCD3800

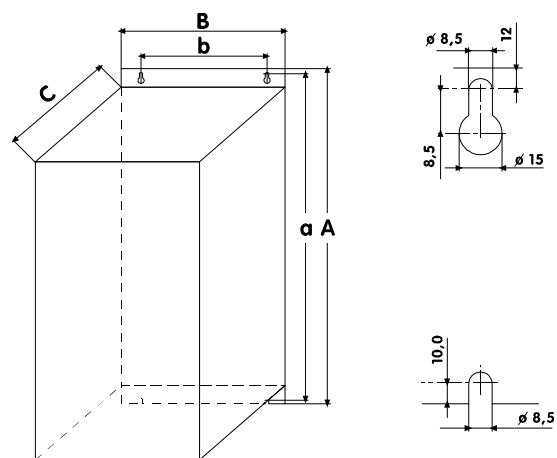
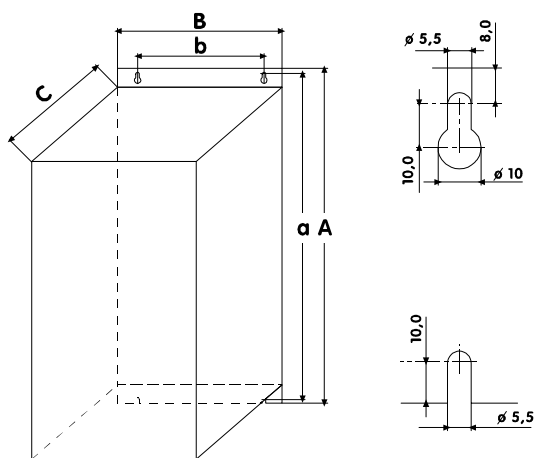



## ■ Design Guide

This section provides data useful in the selection and application of soft starters.

## ■ Reduced voltage starting

When started under full voltage conditions a.c. induction motors initially draw Locked Rotor Current (LRC) and produce Locked Rotor Torque (LRT). As the motor accelerates the current falls and the torque increases to break down torque before falling to full speed levels. Both the magnitude and shape of the current and torque curves are dependent on motor design.

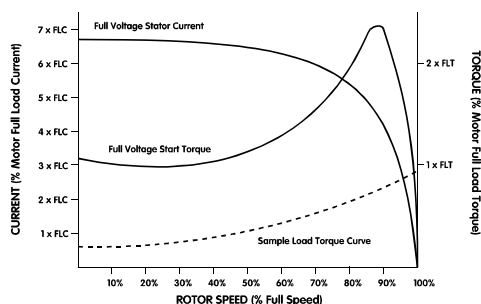

Motors with almost identical full speed characteristics often vary significantly in their starting capabilities. Locked rotor currents range from as low as to 500%, to in excess of 900% of motor FLC. Locked rotor torque range from as low as 70%, to highs of around 230% motor Full Load Torque (FLT).

The motor's full voltage current and torque characteristics set the limits for what can be achieved with a reduced voltage starter. For installations in which either minimising start current, or maximising start torque is critical, it is important to ensure that a motor with low LRC and high LRT characteristics is used.

When a reduced voltage starter is used, motor start torque is reduced according to the following formula.

$$T_{ST} = LRT \times \left( \frac{I_{ST}}{LRC} \right)^2$$

$T_{ST}$  = Start torque

$I_{ST}$  = Start current

LRC = Motor Locked Rotor Current

LRT = Motor Locked Rotor Torque

Start current can be reduced only to the point where the resulting start torque still exceeds the torque required by the load. Below this point motor acceleration will cease and the motor/load will not reach full speed.

The most common reduced voltage starters are;

- Star/Delta starters
- Auto-transformer starters

- Primary resistance starters
- Soft starters

Star/Delta starting is the cheapest form of reduced voltage starting however performance is limited. The two most significant limitations are;

1. There is no control over the level of current and torque reduction, these are fixed at one third of the full voltage levels.
2. There are normally large current and torque transients as the starter changes from star to delta. This causes mechanical and electrical stress often resulting in damage. The transients occur because as the motor is spinning and then disconnected from the supply it acts as a generator with output voltage which may be at the same amplitude as the supply. This voltage is still present when the motor is reconnected in delta configuration, and can be exactly out of phase. The result is a current of up to twice locked rotor current and four times locked rotor torque.

Auto-transformer starting offers more control than the star/delta method, however voltage is still applied in steps. Limitations of auto-transformer starting include;

1. Torque transients caused by switching between voltages.
2. Limited number of output voltage taps restricts the ability to closely select the ideal starting current.
3. High price for models suitable for frequent or extended starting conditions.
4. Cannot provide an effective reduced voltage start for loads with varying start requirements. For instance, a material conveyor may start loaded or unloaded. The auto-transformer starter can only be optimised for one condition.

Primary resistance starters also provide greater starting control than star/delta starters. However, they do have a number of characteristics that reduce their effectiveness. These include;

1. Difficult to optimise start performance when commissioning because the resistance value must be calculated when the starter is manufactured and is not easily changed later.
2. Poor performance in frequent starting situations because the resistance value changes as heat is generated in the resistors during a start. A long cool down period is required between starts.
3. Poor performance for heavy duty or extended starts because heat build up in the resistors changes the resistance value.
4. Cannot provide an effective reduced voltage start for loads with varying start requirements.

Soft starters are the most advanced of the reduced voltage starters. They offer superior control over current and torque as well as incorporating advanced motor protection and interface features.

The main starting advantages soft starters offer are;

1. Simple and flexible control over starting current and torque.
2. Smooth control of voltage and current free from steps or transitions.
3. Capable of frequent starting.
4. Capable of handling changing start conditions.
5. Soft stop control to extend motor deceleration times.
6. Braking control to reduce motor deceleration times.

### ■ Types of soft start control

The term 'soft start' is applied to a range of technologies. These technologies all relate to motor starting but there are significant differences in the methods used and the benefits available. Soft starters can be broken down into the following categories;

- Torque controllers
- Open loop voltage controllers
- Closed loop voltage controllers
- Closed loop current controllers

Torque controllers provide only a reduction in starting torque. Depending on their design they control one or two phases only. As a consequence there is no control of starting current as is provided by the more advanced soft start formats.

Single phase torque controllers must be used with a contactor and motor overload. They are suitable for light applications with low to medium start frequency. Three phase control should be used for repetitive start or high inertia loads because single phase controllers cause increased motor heating during start. This occurs because almost full voltage current flows in the motor winding not controlled by the single phase controller. This current flows for a longer period than during a DOL start resulting in increased motor heating.

Two phase torque controllers must be used with a motor overload but can start and stop the motor without use of a contactor, however voltage is still present at the motor even when it is not running. If installed in this manner it is important to ensure adequate safety measures are taken and that such operation is permitted by local regulations.

Open loop voltage controllers control all three phases and provide both the electrical and mechanical benefits normally associated with soft start. These

systems control the voltage applied to the motor in a preset manner and receive no feedback on starting current. Control of start performance is provided to the users through settings such as, Initial Voltage, Ramp-up time and Dual Ramp-up time. Soft stop is also commonly available and provides the ability to extend motor stopping times.

Open loop voltage controllers must be used with a motor overload and, if required, a line contactor. As such they are a component part that must be integrated with other items to form a complete motor starter.

Closed loop voltage controllers are a variant of the open loop system. They receive feedback on motor start current and use this to stop the voltage ramp when a user set start current limit is reached. User settings and adjustments are the same as for the open loop voltage controllers with the addition of a current limit setting.

Motor current information is also often used to provide a number of current based protection functions. These functions include, motor overload, phase imbalance, electronic shearpin, undercurrent etc. These systems are complete motor starters providing both start/stop control and motor protection.

Closed loop current control is the most advanced form of soft start. Unlike voltage based systems closed loop current technology uses current as the primary reference. The advantages of this approach are precise control of starting current and ease of adjustment. Many of the user settings required by closed loop voltage systems can be made automatically by current based systems.

### ■ MCD3000 control principles

MCD3000 soft starters control all three phases supplied to the motor. They are closed loop current controllers employing constant current algorithms to provide the best in soft start control.

### ■ Understanding soft starter ratings

The maximum rating of a soft starter is calculated so the junction temperature of the power modules (SCRs) does not exceed 125°C. Five operating parameters effect the SCR junction temperature; *Motor Current*, *Start Current*, *Start Duration*, *Number of Starts Per Hour*, *Off Time*. The full rating of a particular soft start model must account for all these parameters. A current rating on its own is not sufficient to describe the capability of a soft starter.

IEC 60947-4-2 details the AC53 utilisation categories for describing a soft starter's ratings. There are two AC53 codes;

- AC53a: for soft starters used without bypass contactors.  
For example, the following AC53a code describes a soft starter capable of supplying a 256 A run current and a start current of 4.5 x FLC for 30 seconds 10 times per hour where the motor runs for 70% of each operating cycle. (Operating cycle = 60 minutes / starts per hour)

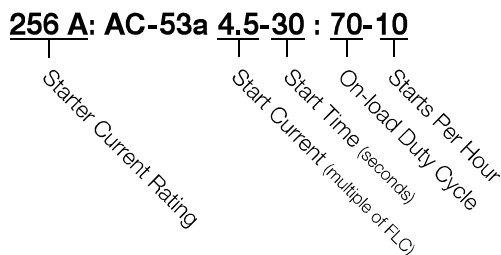

- Starter Current Rating:** Maximum FLC rating of the motor to be connected to the soft starter given the operating parameters specified by the remaining items in the AC53a code.
- Start Current:** The maximum start current that will be drawn during start.
- Start Time:** The time taken for the motor to accelerate.
- On-load Duty Cycle:** The percentage of each operating cycle that the soft starter will run.
- Starts Per Hour:** The number of operating cycles per hour.

- AC53b: for soft starters used with bypass contactors  
For example, the following AC53b code describes a soft starter which, when bypassed, is capable of supplying 145 A run current and a start current of 4.5 x FLC for 30 seconds with a minimum of 570 seconds between the end of one start and the commencement of the next.

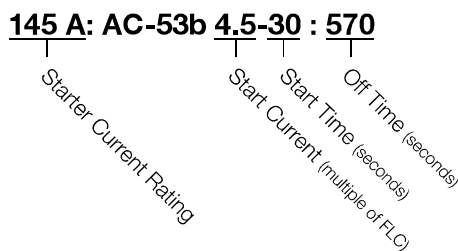

In summary, a soft starter has many current ratings. These current ratings are dependent on the start current and operational performance required by the application.

To compare the current rating of different soft starters it is important to ensure that operating parameters are identical.

■ **Model selection**



**ATTENTION**

To fully understand the model selection procedures it is important to have a good knowledge of the fundamental principles of soft starter ratings. Please read the previous section of this manual, *Understanding soft starter ratings*.

Model selection can be made in two ways. The most appropriate procedure is dependent on the individual circumstances of the application. Technical support is also available from your local supplier.

**Standard model selection procedure**

This method is appropriate for typical industrial applications that operate within the standard MCD3000 ratings of 10 starts per hour, 50% duty cycle, 40°C, <1000 metres.

- Use the table below to determine the typical start current required for the driven load.
- Refer to the Current Ratings tables in the Specifications section of this manual, and use the typical start current identified above to select a MCD3000 model with a FLC rating greater or equal to the motor nameplate FLC.

Application	Typical Start Current
<b>General &amp; Water</b>	
Agitator	4.0 x FLC
Centrifugal Pump	3.5 x FLC
Compressor (Screw, unloaded)	3.0 x FLC
Compressor (Reciprocating, unloaded)	4.0 x FLC
Conveyor	4.0 x FLC
Fan (damped)	3.5 x FLC
Fan (undamped)	4.5 x FLC
Mixer	4.5 x FLC
Positive Displacement Pump	4.0 x FLC
Submersible Pump	3.0 x FLC
<b>Metals &amp; Mining</b>	
Belt Conveyor	4.5 x FLC
Dust Collector	3.5 x FLC
Grinder	3.0 x FLC
Hammer Mill	4.5 x FLC
Rock Crusher	4.0 x FLC
Roller Conveyor	3.5 x FLC
Roller Mill	4.5 x FLC
Tumbler	4.0 x FLC
Wire Draw Machine	5.0 x FLC
<b>Food Processing</b>	
Bottle Washer	3.0 x FLC
Centrifuge	4.0 x FLC
Dryer	4.5 x FLC
Mill	4.5 x FLC

Application	Typical Start Current
Palletiser	4.5 x FLC
Separator	4.5 x FLC
Slicer	3.0 x FLC
<b>Pulp and Paper</b>	
Dryer	4.5 x FLC
Re-pulper	4.5 x FLC
Shredder	4.5 x FLC
<b>Petrochemical</b>	
Ball Mill	4.5 x FLC
Centrifuge	4.0 x FLC
Extruder	5.0 x FLC
Screw Conveyor	4.0 x FLC
<b>Transport &amp; Machine Tool</b>	
Ball Mill	4.5 x FLC
Grinder	3.5 x FLC
Material Conveyor	4.0 x FLC
Palletiser	4.5 x FLC
Press	3.5 x FLC
Roller Mill	4.5 x FLC
Rotary Table	4.0 x FLC
<b>Lumber &amp; Wood products</b>	
Bandsaw	4.5 x FLC
Chipper	4.5 x FLC
Circular Saw	3.5 x FLC
Debarker	3.5 x FLC
Edger	3.5 x FLC
Hydraulic Power Pack	3.5 x FLC
Planer	3.5 x FLC
Sander	4.0 x FLC

**ATTENTION**

The above start current requirements are typical and appropriate in most circumstances.

However, start torque requirements and performance of motors and machines does vary. For greater accuracy use the advanced model selection procedure.

**ATTENTION**

For applications that operate outside the standard MCD3000 ratings of 10 starts per hour, 50% duty cycle, 40°C, <1000 metres consult your local supplier.

**Advanced model selection procedure**

This method uses data on the motor and load to determine the required start current and assumes operation within the standard MCD3000 ratings of 10 starts per hour, 50% duty cycle, 40°C, <1000 metres.

Advanced model selection should be used where typical figures listed in the standard model selection procedure are not considered certain enough. Advanced model selection is also recommended for high inertia applications and installations involving large motors where motor start performance can vary widely.

1. Calculate the required starting torque as a percentage of motor Full Load Torque (FLT).

Generally machine suppliers will be able to provide data regarding the start torque requirements of their machinery. Where this data is not provided as a percentage of motor FLT it will need to be converted.

A motor's full load torque can be calculated as follows

$$\text{Motor FLT (NM)} = \frac{9550 \times \text{Motor kW}}{\text{Motor Full Speed RPM}}$$

$$\text{Motor FLT (lb-ft)} = \frac{7040 \times \text{Motor kW}}{\text{Motor Full Speed RPM}}$$

2. Calculate the minimum start current required by the motor to produce the required torque as calculated above.

$$I_{ST} = LRC \times \sqrt{\frac{T_{ST}}{LRT}}$$



$I_{ST}$  = Minimum required start current  
 $LRC$  = Motor Locked Rotor Current  
 $LRT$  = Motor Locked Rotor Torque  
 $T_{ST}$  = Required start torque



3. Refer to the Current Ratings tables in the Specifications section of this manual. Select a Start Current column within the Current Ratings table that is greater than the required start current calculated above. Use this column to select a MCD3000 model with a FLC rating greater or equal to the motor nameplate FLC.

**Typical applications**

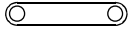
MCD3000 soft starters can offer benefits for almost all motor starting applications. Typical advantages are highlighted in the table below.

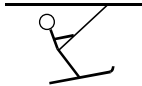
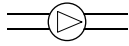
Application	Benefits
Pumps 	<ul style="list-style-type: none"> <li>• Minimised hydraulic shock in pipelines during start and stop.</li> <li>• Reduced starting current.</li> <li>• Minimised mechanical stress on motor shaft.</li> <li>• Undercurrent protection prevents damage from block pipe or low water situations.</li> <li>• Automatic reset functionality ensures continued operation of unmanned pump stations.</li> </ul>

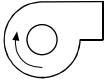
Application	Benefits
	<ul style="list-style-type: none"> <li>Phase rotation protection prevents damage from reverse pump rotation.</li> <li>Instantaneous overload protection prevents damage from debris sucked into the pump.</li> </ul>
Conveyor Belts 	<ul style="list-style-type: none"> <li>Controlled soft start without mechanical shocks, e.g. bottles on a belt do not fall over during starting, minimised belt stretch, reduced counter balance stress.</li> <li>Controlled stop without mechanical shocks. Soft stop.</li> <li>Optimum soft start performance even with varying starting loads, e.g. coal conveyors started loaded or unloaded.</li> <li>Extended mechanical lifetime.</li> <li>Maintenance-free.</li> </ul>
Centrifuges 	<ul style="list-style-type: none"> <li>Smooth application of torque prevents mechanical stress.</li> <li>Reduced starting times over star/delta starting.</li> <li>Reduced stopping times. (D.C.Brake and soft braking).</li> </ul>
Ski Lifts 	<ul style="list-style-type: none"> <li>Jerk free acceleration increases skier comfort and prevents swinging T-bars etc.</li> <li>Reduced starting current allows starting of large motors on a weak power supply.</li> <li>Smooth and gradual acceleration whether the ski lift is lightly or heavily loaded.</li> <li>Phase rotation protection prevents operation in reverse direction.</li> </ul>
Compressors 	<ul style="list-style-type: none"> <li>Reduced mechanical shock extends the life of the compressor, couplings and motor.</li> <li>Limited start current enables large compressors to be started when maximum power capacity is limited.</li> <li>Phase rotation protection prevents operation in reverse direction.</li> <li>Instantaneous overload protection prevents damage possible if liquid ammonia enters the compressor screw.</li> </ul>

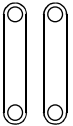
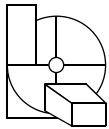
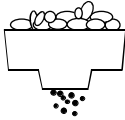
Application	Benefits
Fans 	<ul style="list-style-type: none"> <li>Extended coupling life through reduced mechanical shock.</li> <li>Reduced start current enables large fans to be started when maximum power capacity is limited.</li> <li>Phase rotation protection prevents operation in reverse direction.</li> </ul>
Mixers 	<ul style="list-style-type: none"> <li>Gentle rotation during start-up reduces mechanical stress.</li> <li>The starting current is reduced.</li> </ul>
Bandsaws 	<ul style="list-style-type: none"> <li>Reduced saw band replacement times because the MCD3000 soft braking can stop the motor quickly.</li> <li>Extended saw band life because torque shocks during start are eliminated.</li> <li>Easier saw band alignment. Slow acceleration allows saw bands to be 'tracked' without jogging.</li> <li>Maximum overload capability available for ride through of operating overloads. The MCD3000 motor thermal model can account for the connected motors actual overload capability and will trip only if absolutely necessary.</li> </ul>
Chippers 	<ul style="list-style-type: none"> <li>Reduced starting current.</li> <li>Instantaneous overload trip prevents mechanical damage from jammed loads.</li> <li>Reduced deceleration times through use of braking function.</li> </ul>
Crushers 	<ul style="list-style-type: none"> <li>Maximum overload capability available for ride through of operating overloads. The MCD3000 motor thermal model can account for the connected motors actual overload capability and will trip only if absolutely necessary.</li> <li>Maximum start capability available for starting if crusher stopped while not completely empty. The MCD3000 motor thermal model can account for the connected motors actual overload capability and will allow the motor to provide start torque for the maximum possible time.</li> </ul>

■ **Power factor correction**

If a soft starter is used with static power factor correction it must be connected to the supply side of the starter.



Connecting power factor correction capacitors to the output of the soft starter will result in damage to the soft starter.

■ **Line contactors**

MCD3000 soft starters can operate with or without a line contactor. If installing the MCD3000 without a line contactor, ensure such connection complies with local regulations.

Use of a line contactor or similar physical disconnect provides better off state isolation than the soft starter thyristors. This improves operator safety.

Use of a line contactor also eliminates the potential for extreme supply voltage disturbances to damage the soft starter thyristors while they are in the off state. Voltage disturbances resulting from supply resonance can typically be expected on high impedance supplies with power factor correction. Use of a line contactor is prudent in such conditions.

If using a line contactor and either the soft stop or D.C.Brake functions the line contactor cannot be opened until the end of the stop. The MCD3000 should be used to directly control operation of the line

contactor. Set programmable relay output A or B to the Line Contactor function.

As an alternative to a line contactor, either a circuit breaker with a no volt release coil operated by the MCD3000 N.C. trip output or a motor operated circuit breaker can be considered.

■ **Soft braking**

In addition to the D.C.Brake function MCD3000 soft starters can be configured for 'Soft Braking'. Soft braking provides greater braking torque and lower motor heating. Soft braking should be considered for high inertia loads such as chippers, crushers, bandsaws etc.

To implement soft braking the MCD3000 is employed along with reversing contactors and a rotation sensor. When a stop is called for, the phase rotation of the supply to the starter is reversed and the motor is 'soft started' in reverse thus providing braking torque. The rotation sensor is used to end braking when the motor has stopped rotating.

The MCD3000 secondary parameter set (Par. 25-33) can be used to control braking torque independently of starting parameters. This is done by setting start performance using the primary parameter set (Par. 1-9) and braking performance using the secondary parameter set (Par. 25-33). Closing the Par. Set control input when the stop is initiated then activates the secondary parameter set.

Soft Braking Schematic

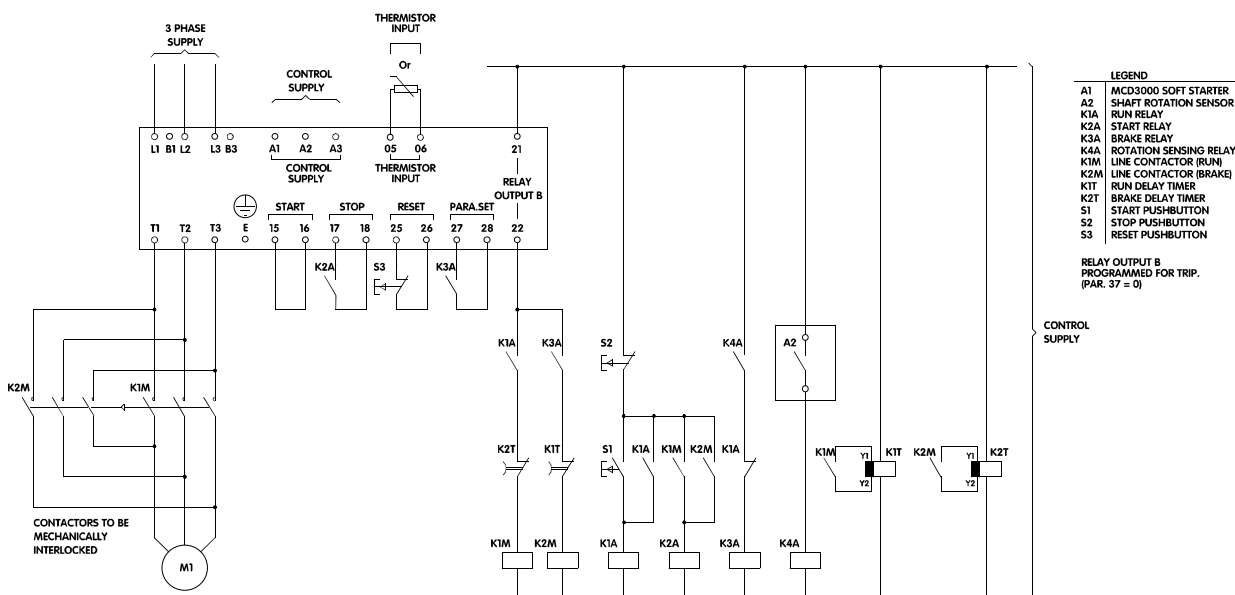

**Fault Procedure**

The MCD3000 Soft Starters include a range of protection functions. Faults identified by these systems are indicated with a trip code on the Local Control Panel display. The following section of this manual explains the trip codes and action required. Procedures for faults not identified with a trip code are detailed in the General Faults section.



The voltage of the soft starter is dangerous whenever the equipment is connected to the mains. Work on the equipment should be carried out by qualified personnel. Before performing any maintenance and repair work, switch off the electrical supply to the device and observe all safety regulations.

**Trip Codes**

When a protection function operates the MCD3000 enters a trip state and displays the following data.

- The trip LED is illuminated
- The [CODE] LED is illuminated indicating the display is showing trip code data



**ATTENTION**

You can view motor temperature as calculated by the MCD3000 motor thermal model by using the [+/-] push buttons to scroll the numeric display between current [AMPS], temperature [TEMP] and trip code [CODE].

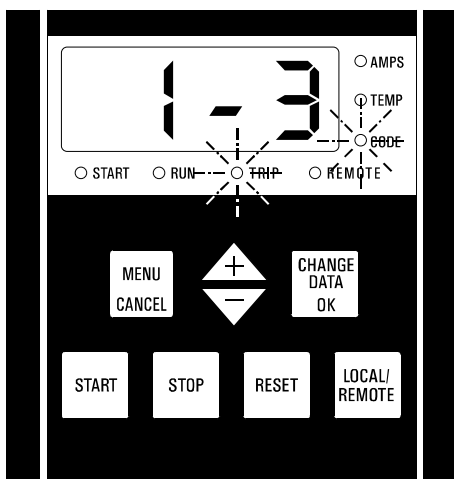

The trip code data is made up of two parts.

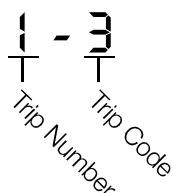

The first digit indicates the trip number. (The MCD3000 has a trip log that records the last eight trip events, trip number 1 is the most recent trip. Refer to the next section of the manual for description of the Trip Log).

The second digit indicates the cause of the trip

Code	Cause & Action
0	Shorted SCR trip. The MCD3000 has detected a shorted SCR. <ul style="list-style-type: none"> <li>• Test the MCD3000 SCRs using the Power Circuit Test described in the Test and measurement procedures chapter later in this section of the manual.</li> <li>• A shorted SCR trip can only be reset by removing control voltage.</li> </ul>
1	Excess start time trip. The start time has exceeded the maximum limit programmed in Par. 10 Excess Start Time Protection. <ul style="list-style-type: none"> <li>• Identify and remedy why the motor is taking longer than normal to accelerate.</li> <li>• Reset the MCD3000</li> <li>• Restart the motor.</li> </ul>
2	Overcurrent trip. The motor has experienced an overload condition that exceeded its thermal capability as programmed in Par. 6 <i>Motor Thermal Capacity</i> . <ul style="list-style-type: none"> <li>• Identify and correct the cause of the overload.</li> <li>• Wait for the motor to cool sufficiently to allow a restart.</li> <li>• Reset the MCD3000.</li> <li>• Restart the motor.</li> </ul> In an emergency situation where it is critical to immediately restart the motor and overload protection of the motor is a secondary concern, the MCD3000 overload protection can be reset by temporarily removing control supply voltage.
3	Motor thermistor trip. Thermistors in the motor have indicated an overtemperature state. <ul style="list-style-type: none"> <li>• Identify and correct the cause of the motor overheating.</li> <li>• Wait for the motor to cool sufficiently to allow a restart.</li> <li>• Reset the MCD3000.</li> <li>• Restart the motor.</li> </ul>

Code	Cause & Action
	If no motor thermistors are connected; <ul style="list-style-type: none"> <li>• Ensure that there is a closed circuit across the MCD3000 motor thermistor input terminals.</li> </ul>
4	Phase imbalance trip. An imbalance in phase currents has exceeded the limits programmed in Par. 7 <i>Phase Imbalance Sensitivity</i> . <ul style="list-style-type: none"> <li>• Check the supply voltage.</li> <li>• Verify the motor circuit.</li> <li>• Reset the MCD3000.</li> <li>• Restart the motor.</li> <li>• Check phase currents.</li> </ul>
5	Supply frequency trip. The supply frequency has varied outside the allowed limits. Refer to Specification section. <ul style="list-style-type: none"> <li>• Identify and correct the cause of the frequency variations. (Note that the loss of the three phase supply is a 0Hz condition and may be the cause of a Supply frequency trip).</li> <li>• Reset the MCD3000.</li> <li>• Restart the motor.</li> </ul>
6	Phase rotation trip. Phase rotation protection has been set and a prohibited phase rotation has been detected. Refer Par. 11 <i>Phase Rotation Protection</i> . <ul style="list-style-type: none"> <li>• Correct the phase rotation.</li> <li>• Reset the MCD3000.</li> <li>• Restart the motor.</li> </ul>
7	Instantaneous overload trip. An instantaneous overload exceeding the limit programmed in Par. 9 <i>Instantaneous Overload Trip Point</i> has been detected. <ul style="list-style-type: none"> <li>• Identify and correct the cause of the instantaneous overload.</li> <li>• Reset the MCD3000.</li> <li>• Restart the motor.</li> </ul>
8	Power circuit fault. <ul style="list-style-type: none"> <li>• Ensure voltage is present on the MCD3000 input terminals (L1, L2 &amp; L3).</li> <li>• Ensure the motor is correctly connected to the MCD3000 output terminals (T1, T2 &amp; T3).</li> <li>• Test the MCD3000 power modules (SCRs) using the SCR Test described later in this section of the manual under the Test and Measurement Procedures heading.</li> </ul>

Code	Cause & Action
9	Undercurrent trip. Motor run current has fallen below the limit programmed in Par. 8 <i>Undercurrent Trip Point</i> . <ul style="list-style-type: none"> <li>• Identify and correct the cause of the undercurrent situation.</li> <li>• Reset the MCD3000.</li> <li>• Restart the motor.</li> </ul>
C	RS485 communications fault The RS485 link with the MCD3000 has been inactive for a time greater than programmed in Par. 24 <i>Serial Communication - RS485 Time Out</i> . <ul style="list-style-type: none"> <li>• Identify and correct the cause of the RS485 failure.</li> <li>• Reset the MCD3000.</li> </ul>
E	EEPROM Read/Write failure. The MCD3000 has been unable to Read/Write to the internal EEPROM. <ul style="list-style-type: none"> <li>• Contact your nearest Danfoss office.</li> </ul>
L	FLC range error The MCD3000 has detected that the motor is connected in the 3 Wire configuration and that Par 1. <i>Motor FLC</i> or Par. 25 <i>Motor FLC</i> has been set in excess of the MCD3000's maximum capability for this connection format. <ul style="list-style-type: none"> <li>• Reduce the motor FLC setting and then reset the MCD3000. Note that the MCD3000 cannot be reset until the FLC setting has been corrected.</li> </ul>
F	Starter overtemperature. An excessive heatsink temperature has been recorded. <ul style="list-style-type: none"> <li>• Ensure all cooling fans are working.</li> <li>• Ensure cooling air is able to flow freely into and out of the starter.</li> <li>• Ensure the temperature of the cooling air entering the MCD3000 does not exceed the rated temperature.</li> <li>• Reset and restart the MCD3000 after allowing time for the heatsink to cool.</li> </ul>
P	Motor connection error. <ul style="list-style-type: none"> <li>• Ensure the motor is correctly connected to the MCD3000.</li> </ul>

**■ Trip Log**



When the MCD3000 enters a trip state, the cause of the trip is recorded in a trip log. The trip log records the cause of the last eight trip events. Each trip event is numbered. The most recent event is numbered 1, while the oldest is numbered 8.

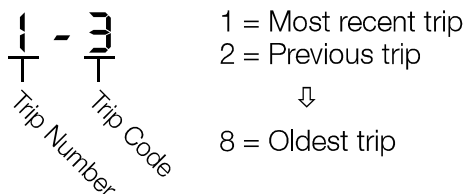

**ATTENTION**

Control voltage must be present to enable the MCD3000 to record the cause of a trip event.

Therefore, trips caused by, or involving a loss of control supply voltage may not be recorded.

To view the trip log;

- Enter the programming mode and move to Par. 45, *Trip Log*.
- Press the [CHANGE DATA/OK] button to view the most recent trip.
- Use the [+/-] buttons to scroll through the trip log.

A 'marker' can be placed in the trip log to enable easy identification of trips that have occurred after the marker has been placed.

To place a marker;

- Enter the programming mode and move to Par. 45 *Trip Log*.
- Press the [CHANGE DATA/OK] button to view the trip log.
- While simultaneously holding down the [+], [-] buttons, press the [CHANGE DATA/OK] button.

The marker is added as the most recent trip and is displayed as the letter 'A' as shown below.

1-A



**ATTENTION**

Markers cannot be placed consecutively. There must be at least one trip between each marker.

■ **General Faults**

Symptom	Cause & Action
Starter will not operate.	<ul style="list-style-type: none"> <li>• Incorrect or no control supply voltage. Ensure the correct voltage</li> </ul>

	<p>is applied. (Terminals A1,A2 &amp; A3).</p> <ul style="list-style-type: none"> <li>• MCD3000 is in programming mode. Exit the programming mode.</li> <li>• Local push buttons not active. If attempting to use the start button on the Local Control Panel, ensure the MCD3000 is in local control mode. (Refer to Par. 20 <i>Local/Remote Mode</i> for details).</li> <li>• Remote inputs not active. If attempting to use the MCD3000 remote inputs, ensure the MCD3000 is in remote control mode. (Refer to Par. 20 <i>Local/Remote Mode</i> for details).</li> <li>• Remote start signal not valid. If attempting to use the remote start input on the MCD3000, ensure the remote contacts are correctly connected and operating properly. Do this by observing the remote</li> </ul>
Starter will not operate.	<p>control input LEDs. The LEDs illuminate when there is a closed circuit. In addition to the start signal there must be a closed circuit across the stop and reset inputs for the starter to function.</p> <ul style="list-style-type: none"> <li>• Restart delay active. A start cannot be initiated within the programmed restart delay period. (Refer to Par. 15 <i>Restart Delay</i> for details).</li> <li>• Auto-Reset active. If there has been a trip and the Auto-Reset function has been turned ON, the MCD3000 will be in Auto-Reset mode. This includes a reset delay period, during which a start cannot be initiated without first resetting the starter. (Refer to Par. 39,40, 41 &amp; 42 <i>Automatic-Reset</i> for details).</li> </ul>
Starter will not enter program mode.	<ul style="list-style-type: none"> <li>• Starter is running. Stop the starter and try again.</li> <li>• Incorrect or no control supply voltage. Ensure the correct supply voltage is applied. (Terminals A1,A2 &amp; A3).</li> </ul>

Symptom	Cause & Action
Program settings cannot be made.	<ul style="list-style-type: none"> <li>• Read Only mode is active. Set Par. 48 <i>Parameter Lock</i> to Read/Write.</li> <li>• Incorrect programming procedure. User programmed settings must be stored using the [CHANGE</li> </ul>

	DATA/OK] button before moving to another parameter.
DOL or uncontrolled start.	<ul style="list-style-type: none"> <li>Power factor correction capacitors connected to starter output. Remove any PFC from the starter output. Check for damage to the soft start power modules by performing the SCR Test as detailed in the next section of this manual.</li> <li>Damaged soft starter power modules. Check the soft start power modules by performing the SCR Test as detailed in the next section of this manual.</li> <li>Damaged soft starter firing circuit. Check the soft start firing circuit by performing the Firing Circuit Test as detailed in the next section of this manual.</li> </ul>
Motor will not accelerate to full speed.	<ul style="list-style-type: none"> <li>Insufficient start current. Check the load. Increase the start current supplied to the motor by adjusting Par. 2 <i>Current Limit</i>.</li> </ul>
Erratic Motor Operation and tripping.	<ul style="list-style-type: none"> <li>Very small motor being controlled by a large starter. The current drawn by very small motors sometimes used to test soft starter installations can be too low to latch the soft starter SCRs. Increase motor size.</li> </ul>
MCD3000 display shows an 'h'	The [START] button on the MCD3000 local control panel is stuck. Release the button to restore normal operation.
Soft stop function ceases before the set ramp time.	The MCD3000 soft stop function has significantly reduced the output voltage to the motor without detecting any reduction in motor speed. This indicates a no, or very light load condition that makes further control of the voltage ineffective, hence the soft stop function has been halted.

the secondary parameter set is being tested Par. 25 *Motor FLC* by the Par. 26 *Current Limit*.

- Initiate a start and measure the actual start current.
- If the measured start current is equal to the calculated current the starter is performing correctly.

**RUN PERFORMANCE TEST;**

This procedure tests for correct operation of the MCD3000 during run.

- Measure the voltage across each phase (L1-T1, L2-T2, L3-T3) of the soft starter. A voltage drop of approximately 2 VAC or less indicates the starter is performing correctly.

**POWER CIRCUIT TEST:**

This procedure tests the MCD3000 power circuit including the SCR, firing loom and printed circuit board.

- Disconnect the incoming supply (L1, L2, L3 and control voltage) from the starter.
- Disconnect the motor cables (T1, T2,T3) from the starter.
- Ensure the firing looms remain plugged in during the tests.
- Using a 500 VDC insulation tester (low voltage ohm meters or multi-meters are not adequate), measure the resistance between the input and output on each phase (L1-T1, L2-T2, L3-T3). The resistance should be close to 33k $\Omega$ .
- If the resistance measured across the SCR measures below about 10k $\Omega$  the SCR should be replaced.
- If the resistance measured across the SCR is greater than 33k $\Omega$  there could be a control PCB or firing loom fault.

**CONTROL INPUT TEST;**

This procedure verifies the integrity of circuits connected to any of the remote control inputs. Start, Stop, Reset and Par. Set.

- Using a volt meter measure across each input. If 24VDC is measured when the circuit is closed, the switch/control is connected incorrectly or is faulty.

**■ Test and measurement procedures**

The following tests and measurements can be used to verify starter operation.

**START PERFORMANCE TEST;**

This procedure tests for correct operation of the MCD3000 during start.

- Calculate the expected start current by multiplying Par. 1 *Motor FLC* by the Par. 2 *Current Limit* or, if



